

## Draining ATF and filling up after repairs

### Special tools and workshop equipment required

- ◆ Hook -3438-

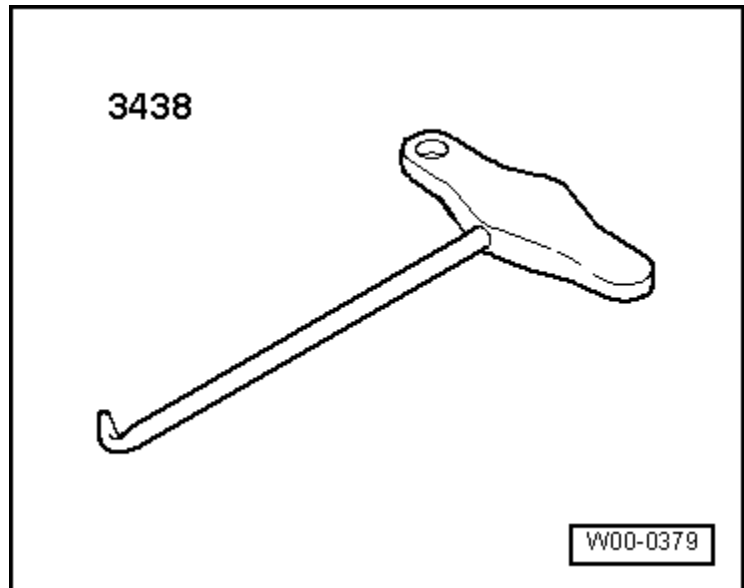

- ◆ Used oil collection and extraction unit -V.A.G 1782-

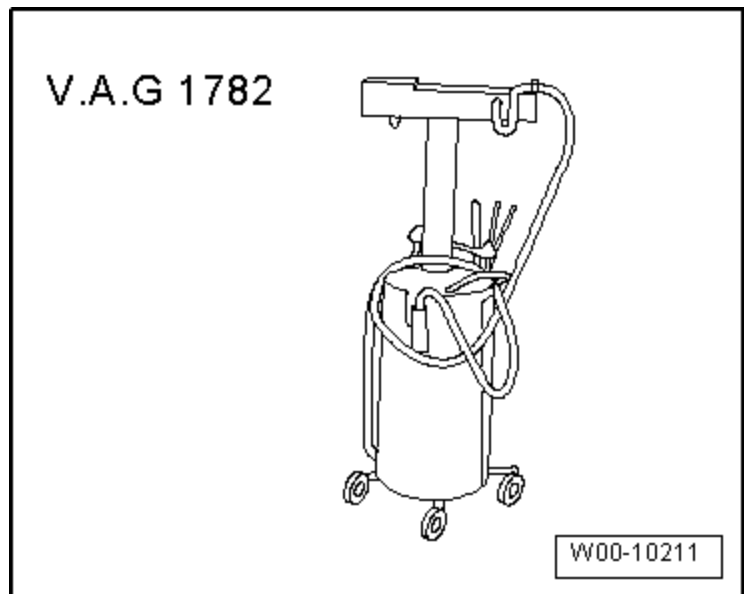

- ◆ ATF charging device for CVT gearboxes -VAS 5162-
- ◆ Safety goggles

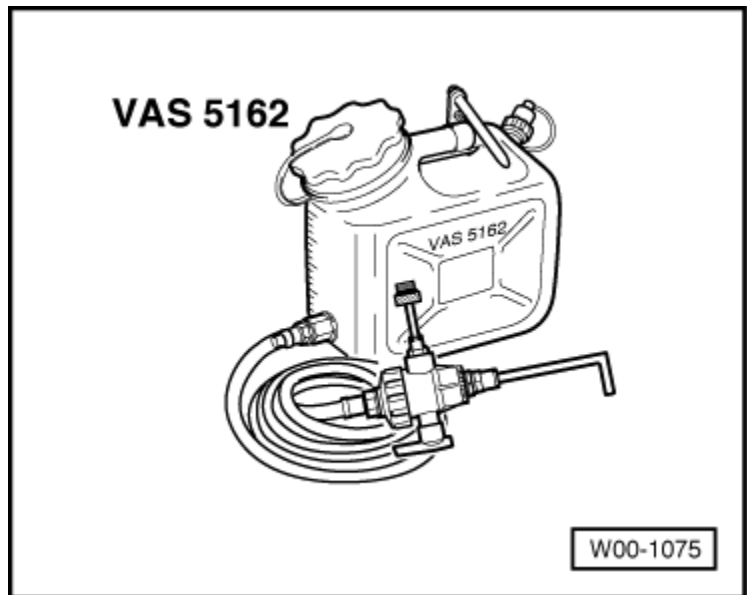

## Preparations:

**Caution**

**Risk of damage to the gearbox.**

**The ATF required for the multitronic 0AW gearbox is different to the ATF used for fixed-ratio automatic gearboxes. Only the ATF available as a replacement part for the “multitronic 0AW, front-wheel drive” gearbox may be used. ATF specifications and capacities → **Chapter**.**

**Note**

- ◆ The illustration on the reservoir of the ATF charging device for CVT gearboxes -VAS 5162- displays a warning in the top left corner to use **ONLY** the ATF specially formulated for CVT gearboxes.
- ◆ The illustration also shows the steps to follow when filling up; these are also described below.

**Caution**

**Risk of damage to the gearbox.**

- ◆ **The engine must not be started if only a little or no ATF remains in gearbox after repair work or after excessive ATF leakage.**
- ◆ **Do not run engine or tow vehicle when there is no ATF in the gearbox.**
- ◆ **In this case you need to fill the gearbox**

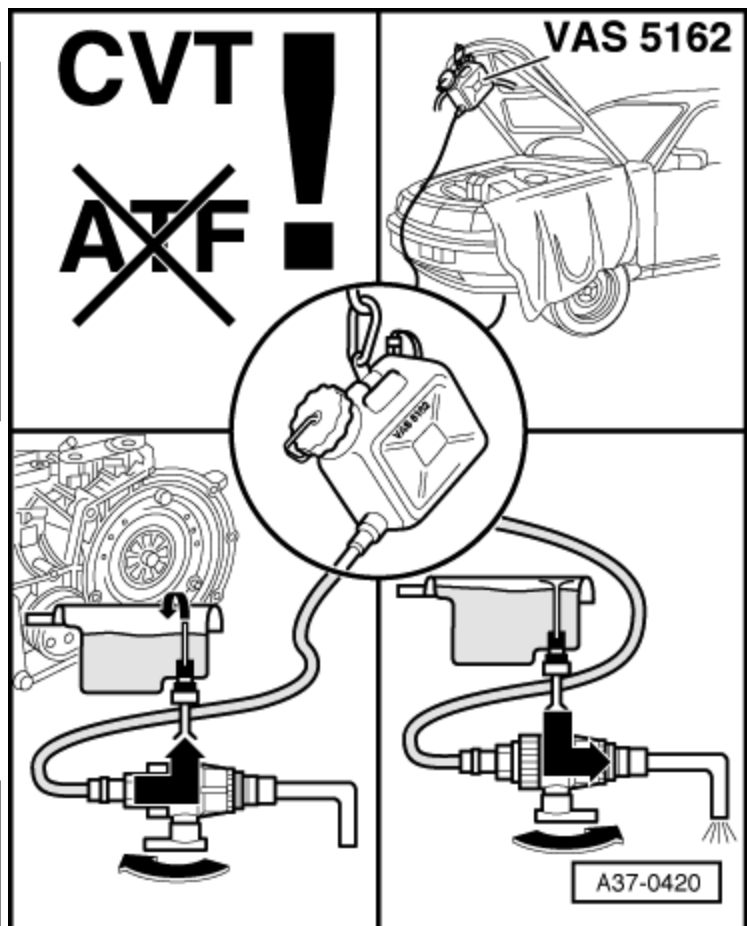

**first with 5.5 ... 6 litres of ATF.**

- Different versions have ATF inspection plugs -A- of different lengths. The ATF inspection plug must be renewed after checking the ATF level. Always select correct version according to gearbox code letters in → [Electronic parts catalogue](#). To prevent damage to the gearbox, please check the new ATF inspection plug by comparing it with the old one.

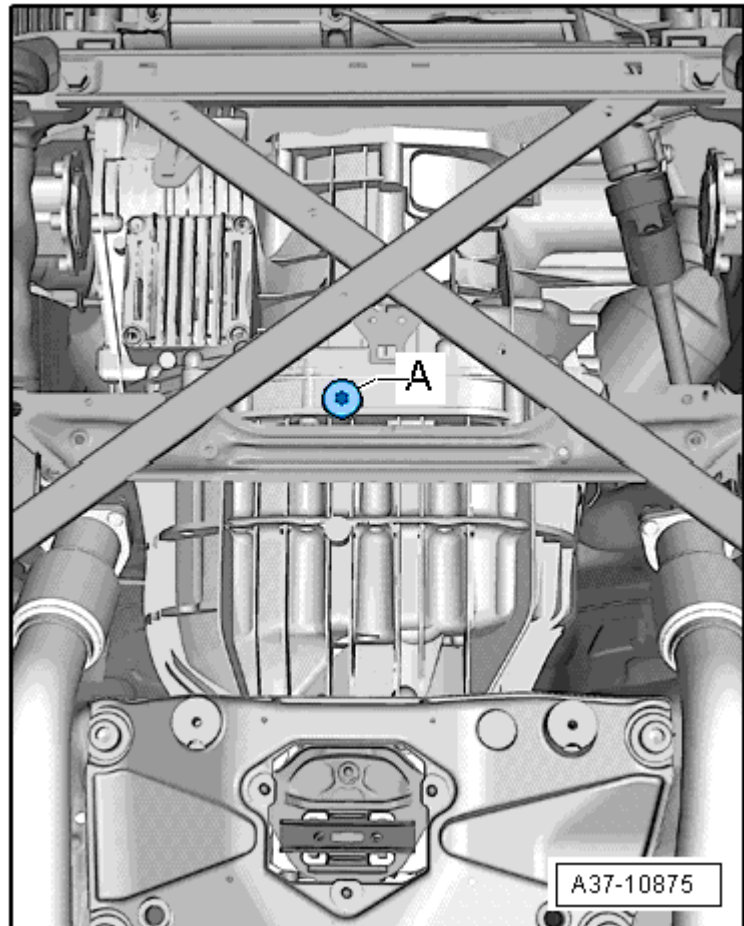

### Procedure

- Engine not running.
- Vehicle must be absolutely horizontal (drive it onto a four-pillar lifting platform or over an inspection pit).
- Selector lever at position "P".
- Electronic parking brake applied.
- Remove noise insulation (rear) → [Rep. Gr.66](#).
- Place used oil collection and extraction unit - V.A.G 1782- below gearbox.



### **WARNING**

**Risk of eye injury.**

**Wear safety goggles.**

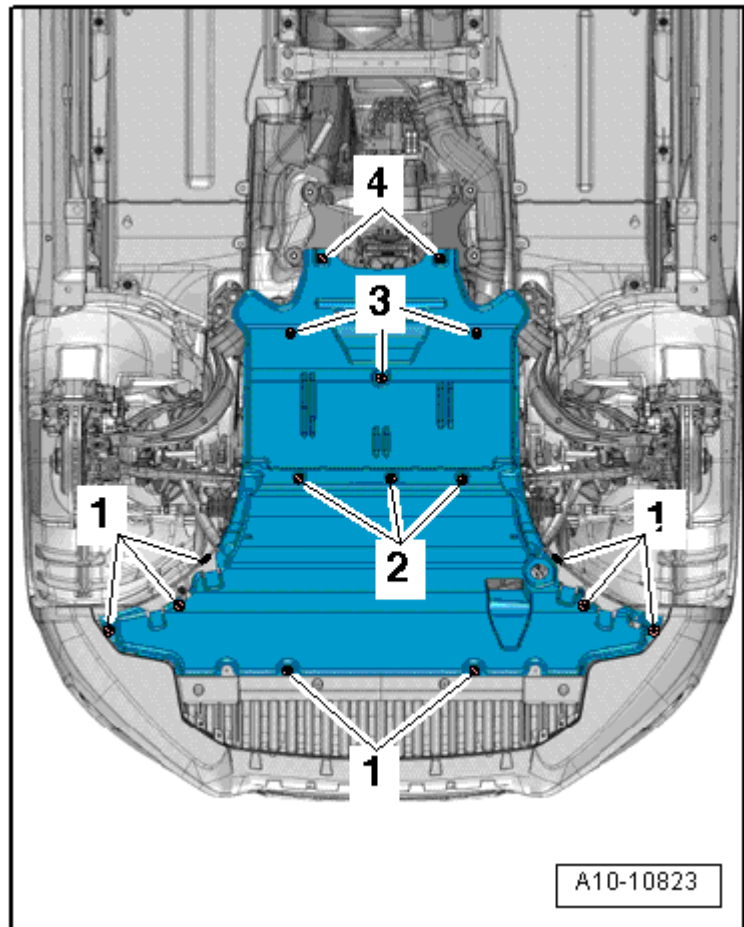

- Unscrew ATF inspection plug -A-.
- Drain ATF.

**Note**

Please observe requirements for disposal.

**Note**

Different versions have different ATF inspection plugs and different fluid level pipes. Always select correct version according to gearbox code letters in → [Electronic parts catalogue](#).

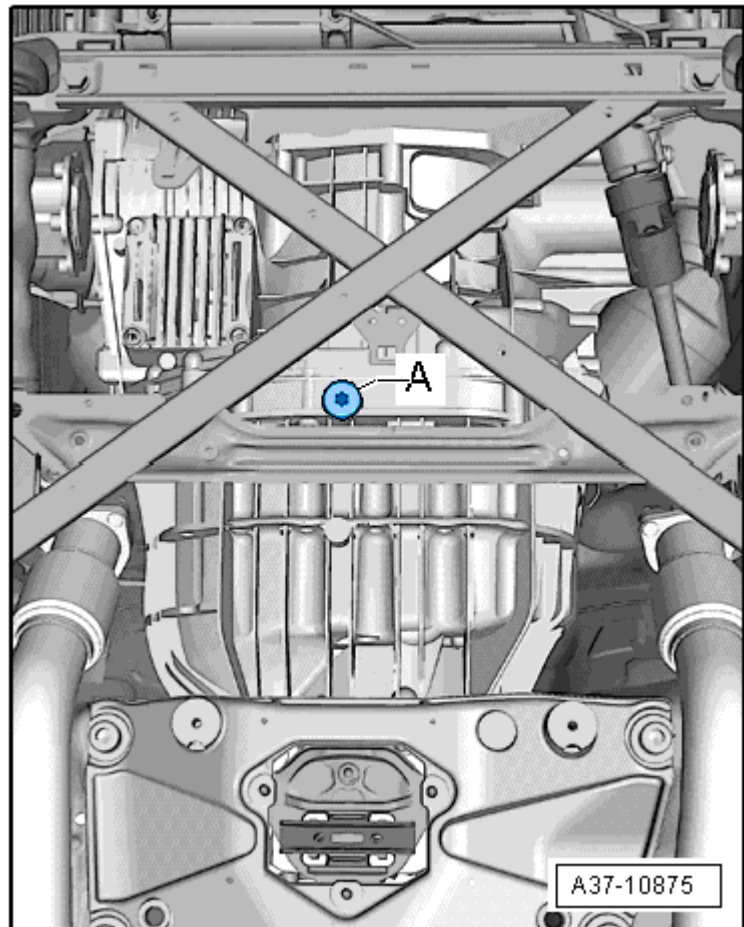
**Gearbox with long, curved fluid level pipe:**

- Pull fluid level pipe -A- out of ATF inspection hole using hook -3438- and allow remaining ATF to drain off.

**Note**

*Illustration shows sectional view from side.*

- The fluid level pipe must be renewed.

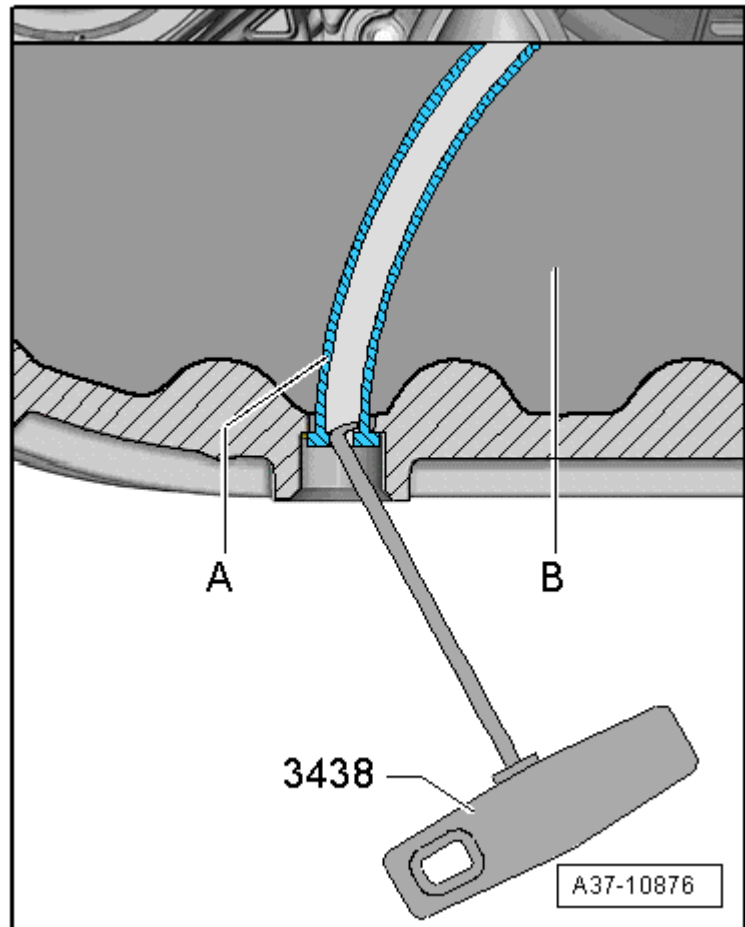

- Press new fluid level pipe -A- into ATF inspection hole -B- by hand.

Installation position: large lug -1- on fluid level pipe should face recess -2- in ATF inspection hole.

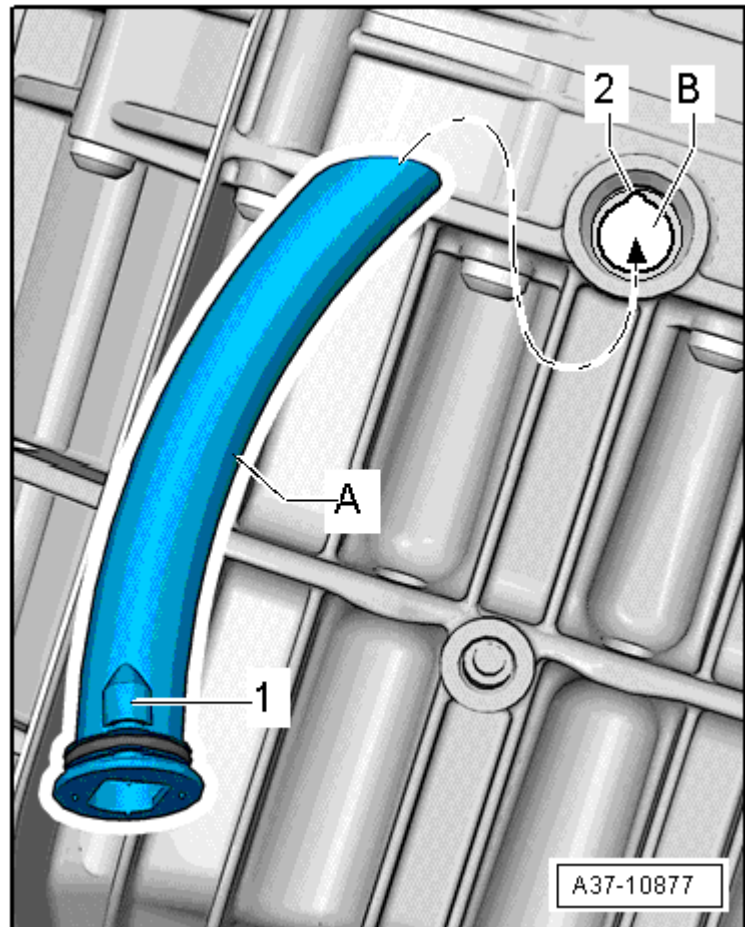
**Gearbox with short, straight fluid level pipe:**

- Pull fluid level pipe -A- out of ATF inspection hole using hook -3438- and allow remaining ATF to drain off.

**Note**

*Illustration shows sectional view from side.*

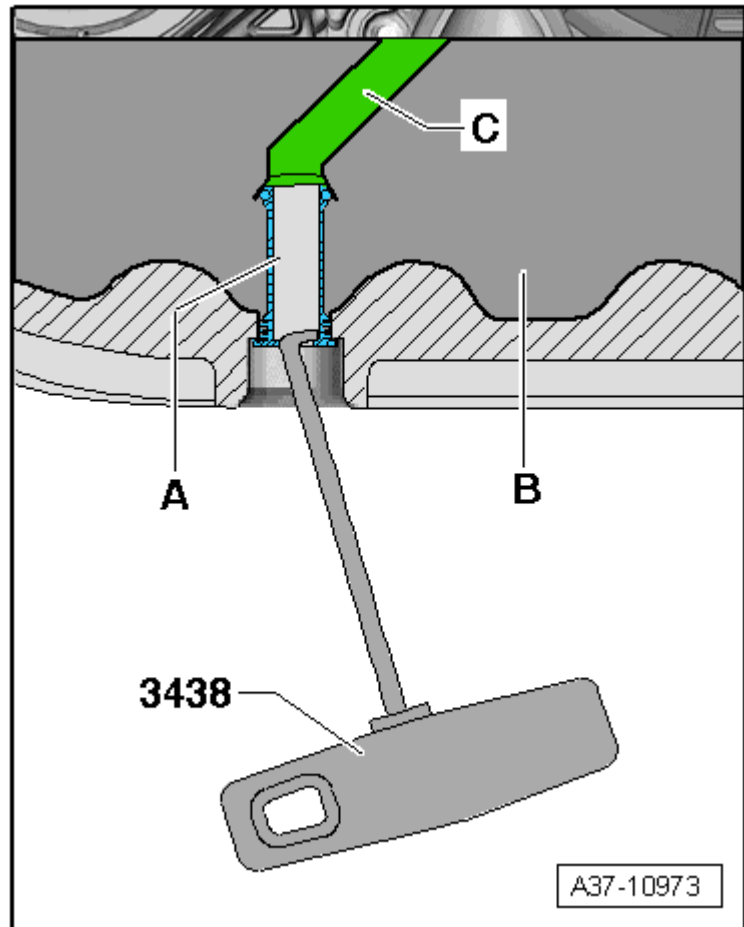

- Fluid level pipe -A- must be renewed.
- O-ring -1- must be correctly fitted in groove on fluid level pipe.
- Press new fluid level pipe -A- into ATF inspection hole -B- straight by hand.

**Note**



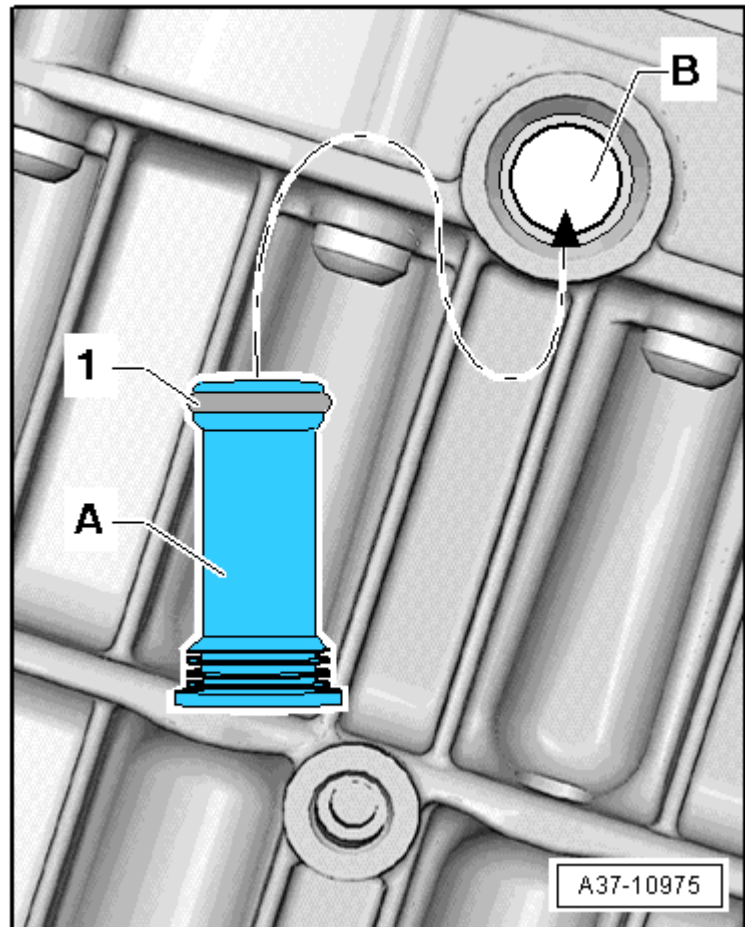

- ◆ O-ring on fluid level pipe -A- provides seal between this pipe and fluid level pipe -C-. Only then can the ATF level be topped up correctly.
- ◆ The hook -3438- can be disregarded for installation.

Continued for all fluid level pipes:

#### Filling gearbox with ATF



#### Caution

**Risk of damage to the gearbox.**

- ◆ **The ATF required for the multitronic 0AW gearbox is different to the ATF used for fixed-ratio automatic gearboxes. Only the ATF available as a replacement part for the “multitronic 0AW, front-wheel drive” gearbox may be used.**
- ◆ **For the correct type, refer to → [Electronic parts catalogue](#).**
- ◆ **The ATF charging device must be clean and the ATF must not be mixed with**

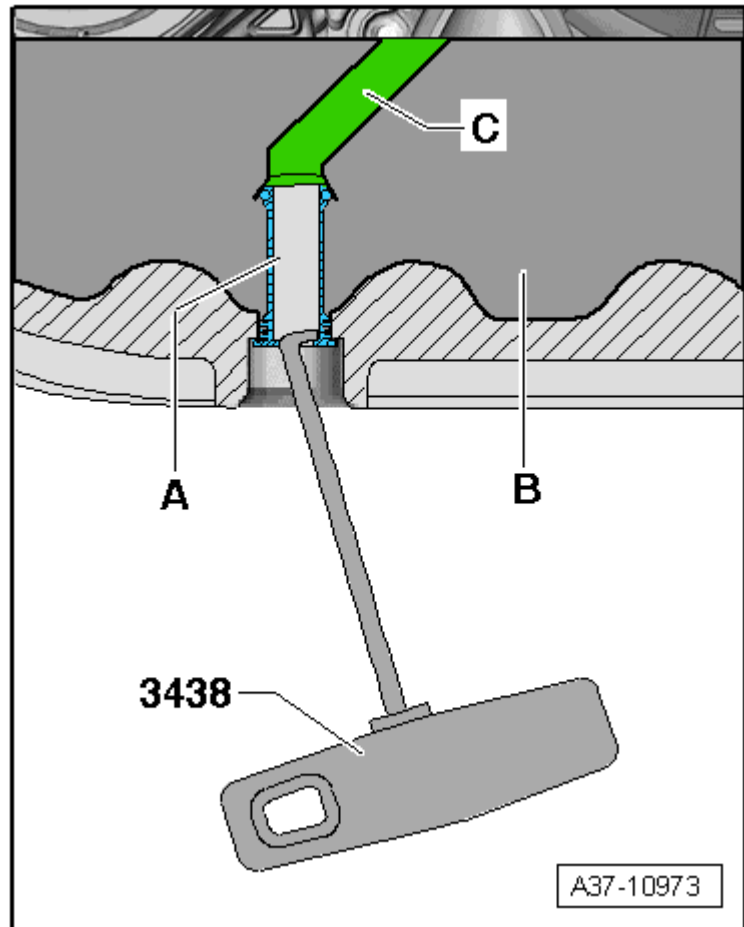
**other types of ATF!****Note**

- ◆ *The illustration on the reservoir of the ATF charging device for CVT gearboxes -VAS 5162- displays a warning in the top left corner to use **ONLY** the ATF specially formulated for CVT gearboxes.*
- ◆ *The illustration also shows the steps to follow when filling up; these are also described below.*

**Note**

*Before fitting a replacement gearbox, always blow through the ATF cooler and ATF pipes with compressed air (not more than 10 bar)*

*→ Chapter.*

- Fill ATF charging device for CVT gearboxes - VAS 5162- with ATF for “multitronic 0AW” gearbox.

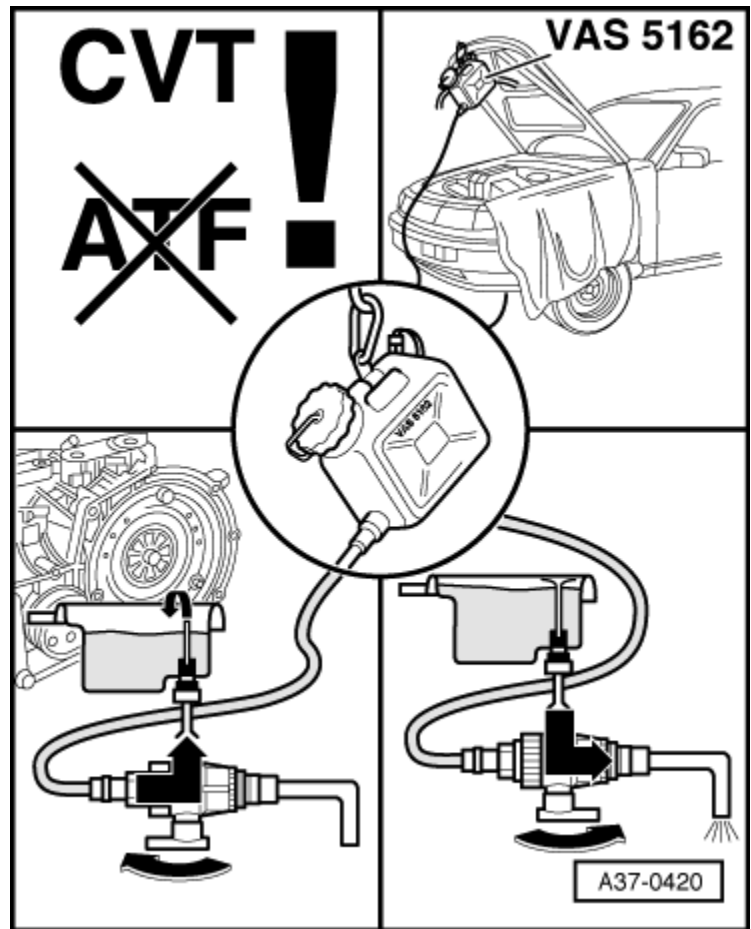

- Attach filled reservoir of ATF charging device for CVT gearboxes -VAS 5162- at the highest possible point on the vehicle.

**Note**

*The stopcock on ATF charging device for CVT gearboxes -VAS 5162- must be closed.*

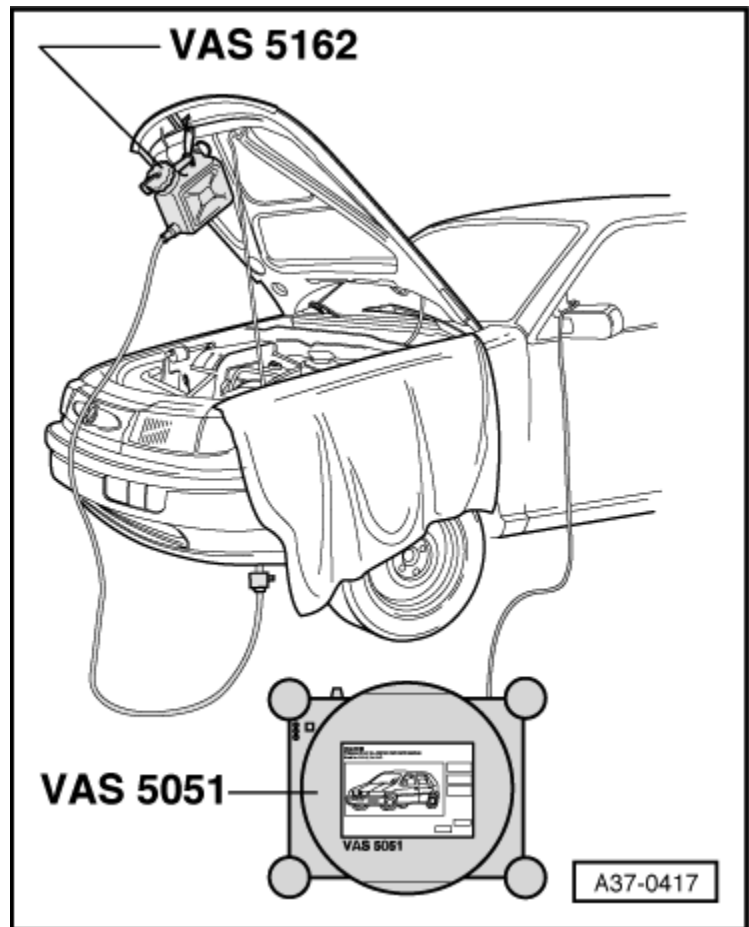

- Remove O-ring -1- at connection -2- on ATF charging device for CVT gearboxes -VAS 5162-.



### Caution

***There is a risk of filling the gearbox incorrectly.***

- ◆ ***The connection -2- must be screwed hand-tight all the way into the inspection hole on the gearbox with the O-ring removed.***
- ◆ ***The O-ring must be removed at the connection -2- so that the fluid level pipe in the inspection hole can be pressed into the upper position.***
- ◆ ***Only then can the ATF level be checked and topped up correctly.***

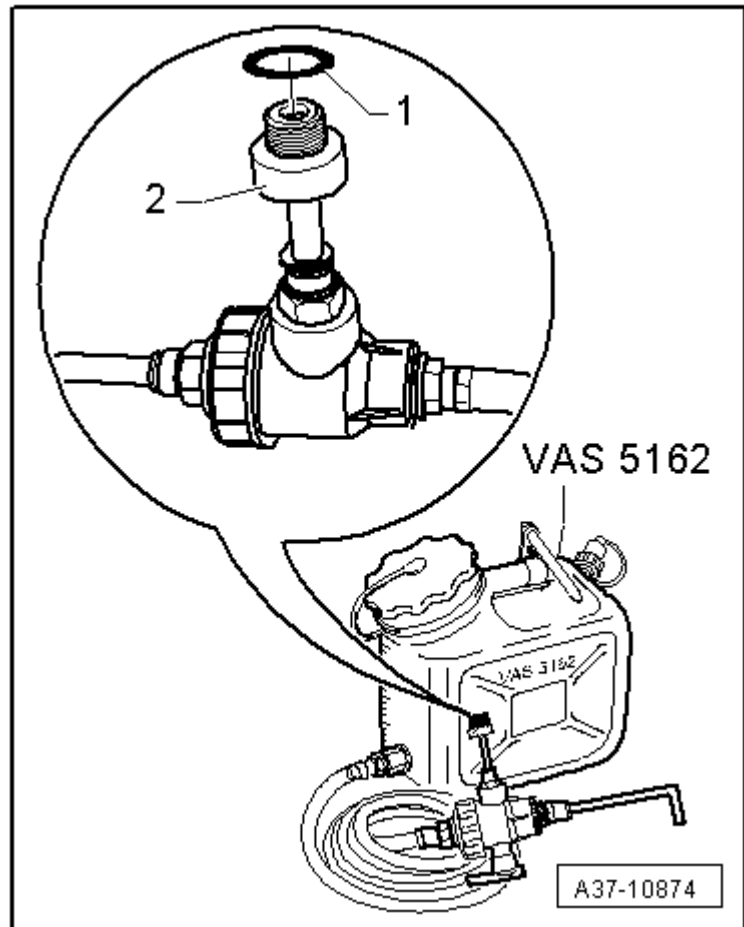

- With O-ring removed, screw connection of ATF charging device for CVT gearboxes -VAS 5162- hand-tight all the way into threaded hole for ATF inspection plug.



#### Note

*This will push the fluid level pipe into the correct installation position.*

- Turn stopcock in direction of filling hose -lower arrow-. ATF flows into gearbox.
- Fill gearbox with at least 5.5 ... 6 ltr. of fresh ATF.
- Shift selector lever into position "P".



#### Caution

**Rev engine up to approx. 2500 rpm immediately after starting.**

- ◆ **The engine must be revved up to vent air from the ATF pump after performing repairs on the gearbox.**
- ◆ **If the engine is not revved up, the pump**

***will run briefly without ATF and may be damaged.***

- Start engine.
- Press accelerator pedal to rev engine briefly up to 2500 rpm.
- Check and top up ATF level → **Chapter**.



**Note**

*Observe all notes and test requirements for "Checking and correcting ATF level".*

