

**ZF-5HP-24  
DIAGNOSTIC INFORMATION**

**FOUND IN:**

- BMW 5 Series E39, 7 Series E38, 8 Series E31 ..... 95-Current*
- Jaguar XK8 (X100), ..... 96-Current*
- Jaguar XJ8 (X300), ..... 97-Current*
- Audi A8 (All Wheel Drive 5HP-24A) ..... 96-Current*

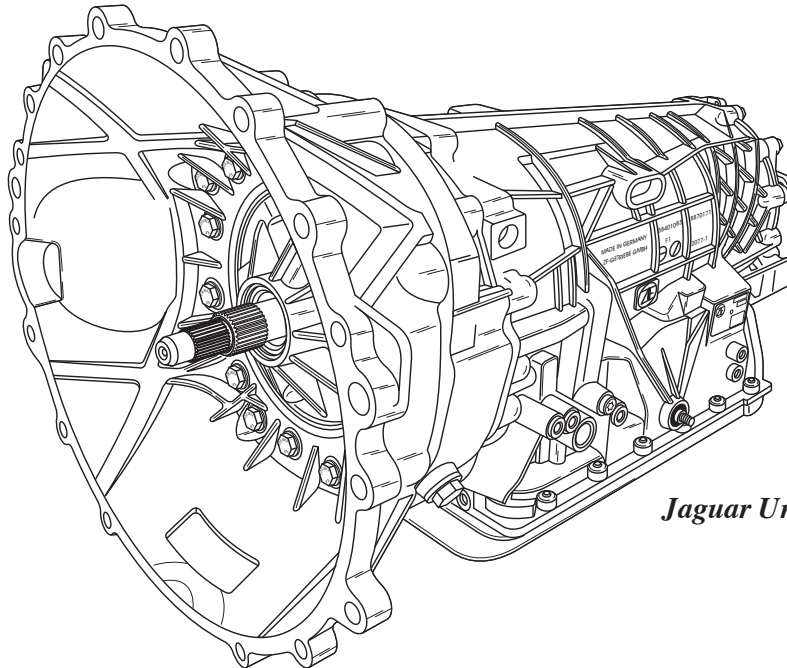

*Jaguar Unit Shown*

*This transmission is manufactured in Germany by ZF and carries the BMW designation A5S 440Z. The A5S 440Z is an electronically controlled, five speed automatic transmission with a lock-up clutch type torque converter. Three planetary gear sets (Wilson Gearing), three rotating multiple disc clutches, three multiple disc brake clutches, and one sprag clutch (Freewheel) are used to provide the five forward speeds and reverse.*

**Key to designation:**

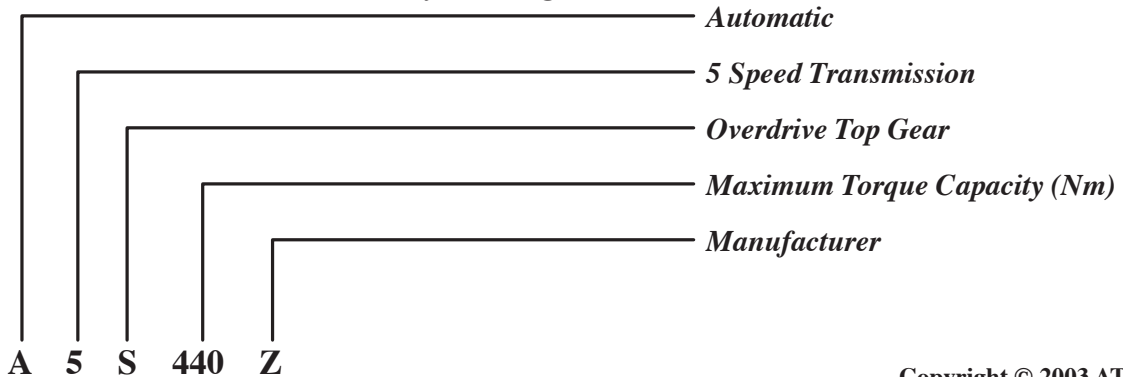

Copyright © 2003 ATSG

Figure 97



## **TECHNICIANS DIAGNOSTIC GUIDE BMW, AUDI, PORSCHE**

*Refer to Figure 98 for Clutch and Band Application Chart.*

*Refer to Figure 99 for Manual Shift Lever Operation, and Failsafe Operation.*

*Refer to Figures 100, and 101 for Solenoid identification and both MV Solenoid Operation and EDS Solenoid Operation and Tests.*

*Refer to Figure 102 for wiring harness identification, internal wiring schematic, and transmission case connector pin identification and functions.*

*Refer to Figure 103 for Shift Solenoid Application chart. Notice that EDS 1 Solenoid is used for line pressure control, and MV-4 is used for converter clutch.*

*Refer to Figure 104 for EDS Solenoid "Principles of Operation", as some are normally open and some are normally closed.*

*Refer to Figure 105 for internal components resistance chart, with the pins identified for both the transmission case connector and the Electronic Control Unit.*

*Refer to Figure 106 for Upper Valve Body exploded view and identification of valves.*

*Refer to Figure 107 for Lower Front Valve Body exploded view and identification of valves.*

*Refer to Figure 108 for Lower Rear Valve Body exploded view and identification of valves.*

*Refer to Figures 109, 110, and 111 for valve body retainer locations in the various valve bodies.*

*Refer to Figure 112 for Channel Plate screen location on the upper side.*

*Refer to Figure 113 for the locations of the orifices, checkballs, screens, and the check valves and springs that are located in the channel plate.*

*Refer to Figure 114 for external pressure tap locations in the main case.*

*Refer to Figure 115 for Pump Volume Control Valve location, in the pump cover.*

*Refer to Figure 116 for explanation of Pump Volume Control Valve operation.*

*Refer to Figure 119 for all valve body spring specifications, as observed in a used valve body.*



**TECHNICIANS DIAGNOSTIC GUIDE  
BMW, AUDI, PORSCHE**

**ZF-5HP-24 INTERNAL COMPONENT APPLICATION CHART**

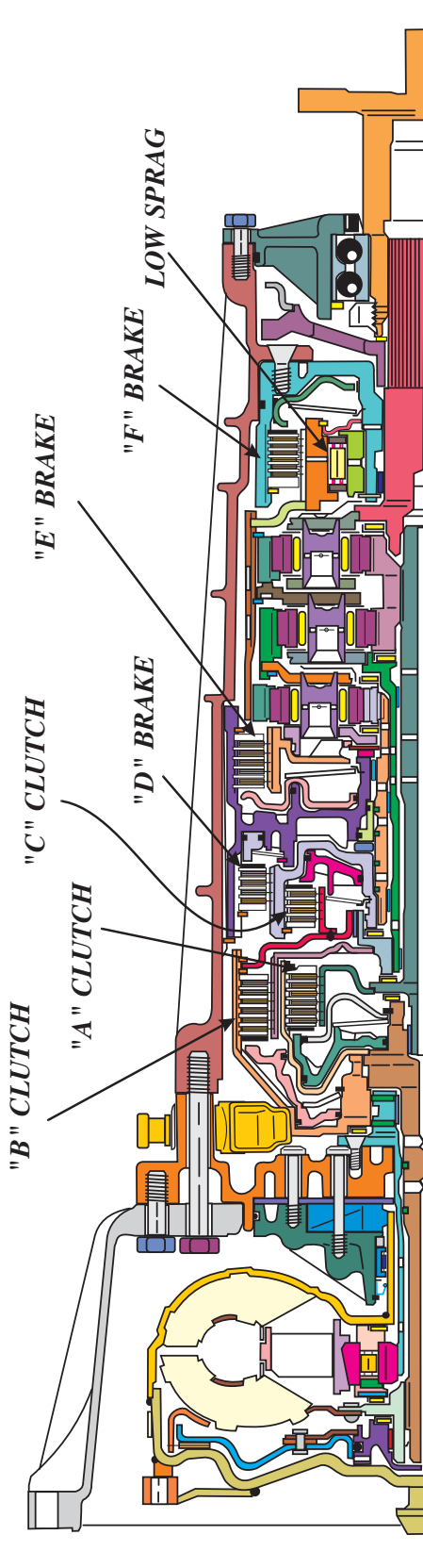

**APPLICATION CHART**

GEAR	"A" CLUT	"B" CLUT	"C" CLUT	"D" BRAK	"E" BRAK	"F" BRAK	LOW SPRAG	GEAR RATIO
PARK						ON		
REV			ON			ON		4.10:1
NEUT						ON		
D-1ST	ON						HOLD	3.57:1
D-2ND	ON				ON			2.20:1
D-3RD	ON			ON				1.51:1
D-4TH	ON	ON						1.00:1
D-5TH		ON		ON				0.80:1
M-1	ON					ON	HOLD	3.57:1

Copyright © 2003 ATSG

Figure 98



**SELECTOR LEVER POSITIONS**

**P** = *Park*, and should only be selected when the vehicle is at a standstill. First apply the hand brake, and then select the Park position with the manual lever. Refer to Figure 99.

**R** = *Reverse*, and should only be selected when the vehicle is at a standstill with engine at idle. Refer to Figure 99.

**N** = *Neutral*, and may be selected when the vehicle is at a standstill, but first applying the handbrake. May also be selected while vehicle is moving, to restart the engine or to counteract a skidding concern. Refer to Figure 99.

**D** = *Drive*, is the standard position for normal driving in the XE program (AGS) and provides automatic upshifts from 1st to 5th and automatic downshifts from 5th to 1st gear. The adaptive transmission control (AGS) system contains various driving programs such as Stop and Go, Trailer Towing, Mountain Driving, City Driving and Highway Driving (constant speed). These programs are selected by the Electronic Control Unit (ECU), which automatically modifies the transmissions shift characteristics according to rolling resistance, engine load, accelerator pedal movement and vehicle speed. The standard "Drive" position is position "1", as shown in Figure 99.

**"S" - Program**

The "S" Program is a performance oriented program, where the gear changing characteristics of the transmission are moved up to higher engine speeds. To select the "S" Program, the selector lever is shifted to the left-hand gate (position "2" in Figure 99), without moving shift lever towards plus or minus. The "S" Program provides automatic upshifts from 1st to 4th and automatic downshifts from 4th to 1st gear. 5th gear is inhibited when the "S" Program is selected.

**"M" - Program**

The "M" Program is a manual shift program which is activated by simply pushing the selector lever towards the minus sign for sequential downshifts and towards the plus sign for sequential upshifts, while the shift lever is in the left-hand gate (position "2" in Figure 99). It is possible to drive off in 1st gear, 2nd gear or 3rd gear, however, 4th gear can be manually selected only at a speed of approximately 40 km per hour and 5th gear at approximately 60 km per hour.

**4th Gear**, Select this position if the transmission tends to hunt between 5th-4th/4th-5th gears under certain driving conditions.

**3rd Gear**, Select this position if the transmission tends to hunt between 3rd and 5th gears under certain driving conditions. Also recommended for lengthy descents in mountainous areas.

**2nd Gear**, Select this position when driving over mountain passes with lengthy ascents and descents.

**1st Gear**, This position can be selected for engine braking effect, depending on vehicle speed.



**TECHNICIANS DIAGNOSTIC GUIDE  
BMW, AUDI, PORSCHE**

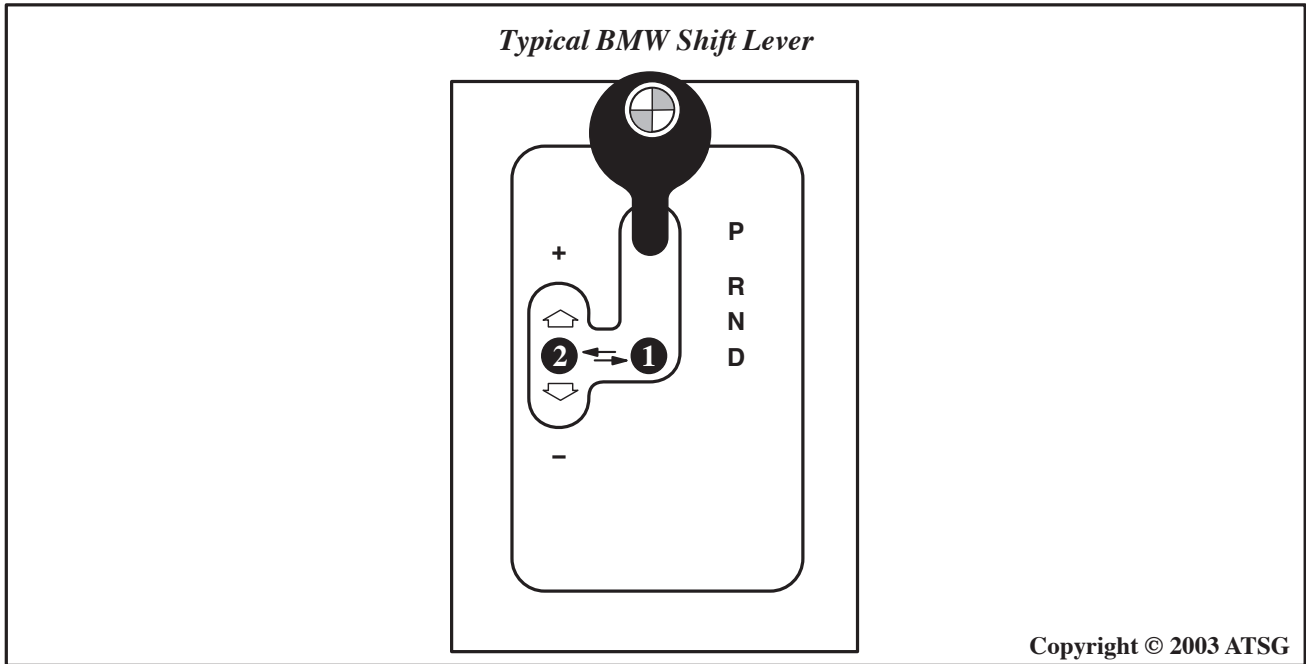

Figure 99

***FAILSAFE OPERATION:***

When a system fault is detected which would impair normal reliable operation, the transmission control module interrupts the power supply to Pin 12 at the transmission case connector. The transmission control module also alerts the driver of any faults by signaling the vehicle's "check control" system. To enable the vehicle to be driven to a repair shop, the following manual gear selections are permitted:

<i>Selector Lever Position</i>	<b>P R N D 4 3 2</b>
<i>Actual Gear Obtained</i>	<b>P R N 5 5 5 5</b>



**TECHNICIANS DIAGNOSTIC GUIDE  
BMW, AUDI, PORSCHE**

**MV1, 2 AND 3**

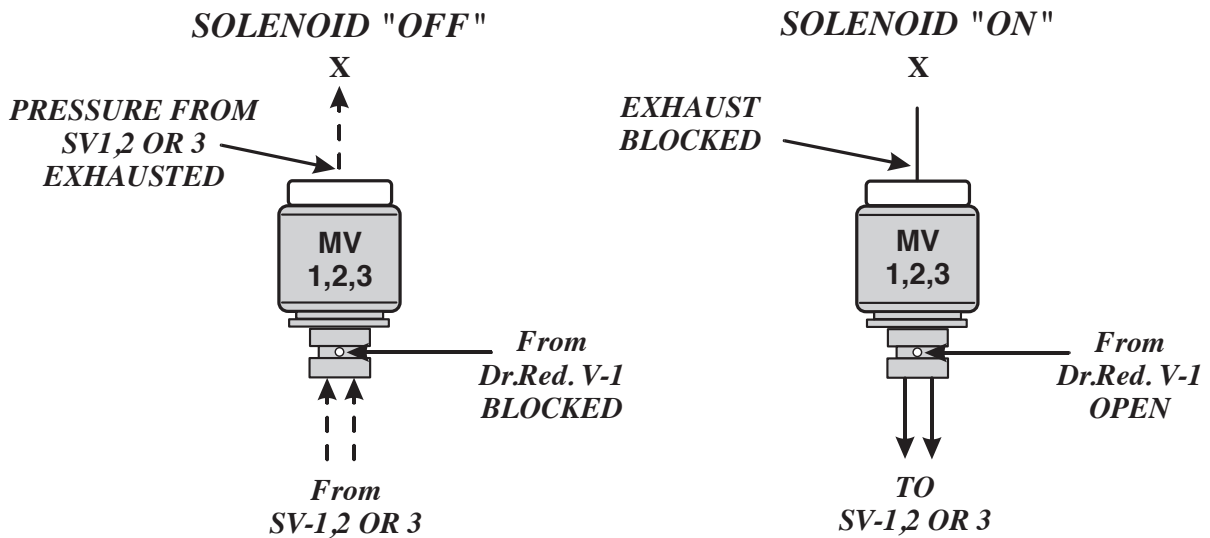

**SUMMARY:**

When MV 1, 2 or 3 is "OFF" Solenoid reducing pressure, from Dr.Red. V-1, is blocked by the solenoid and oil pressure from SV 1, 2 or 3 is exhausted at the rear of the solenoid.  
When MV 1, 2 or 3 is "ON" Solenoid reducing pressure, From Dr.Red. V-1, is open through the solenoid and is applied to SV 1, 2 or 3. The exhaust at the rear of the solenoid is closed.

**EDS 2, 3, 4, 5,**

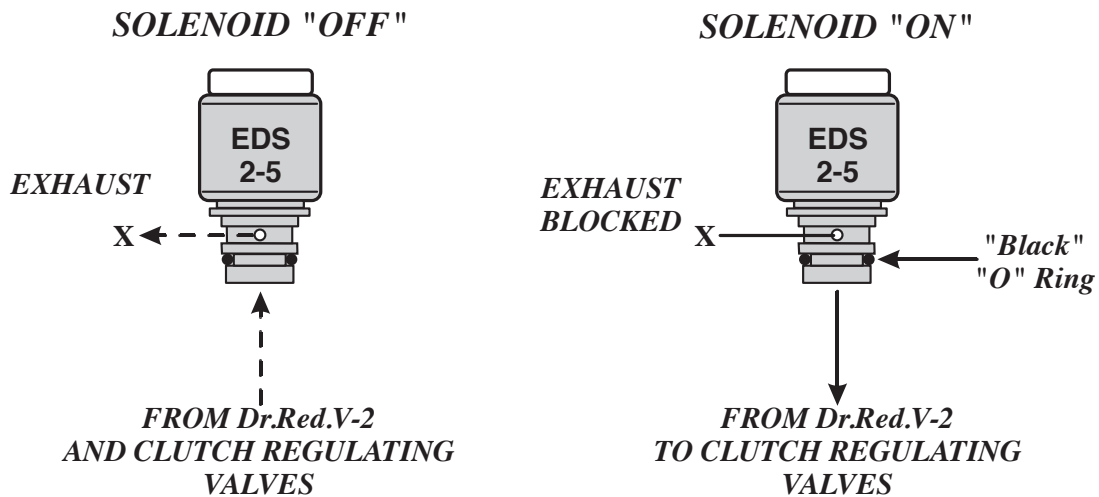

**SUMMARY:**

When EDS 2 thru 5 solenoids are "OFF" they exhaust orificed solenoid reducing pressure, from Dr. Red. V-2, and the oil pressure from the clutch regulating valves releasing them.  
When EDS 2 thru 5 solenoids are "ON" the exhaust is blocked by the solenoid and solenoid reducing pressure, from Dr. Red. V-2, is applied to operate clutch regulating valves.

Copyright © 2003 ATSG

Figure 100



**TECHNICIANS DIAGNOSTIC GUIDE  
BMW, AUDI, PORSCHE**

**EDS 1 (Line Pressure)**

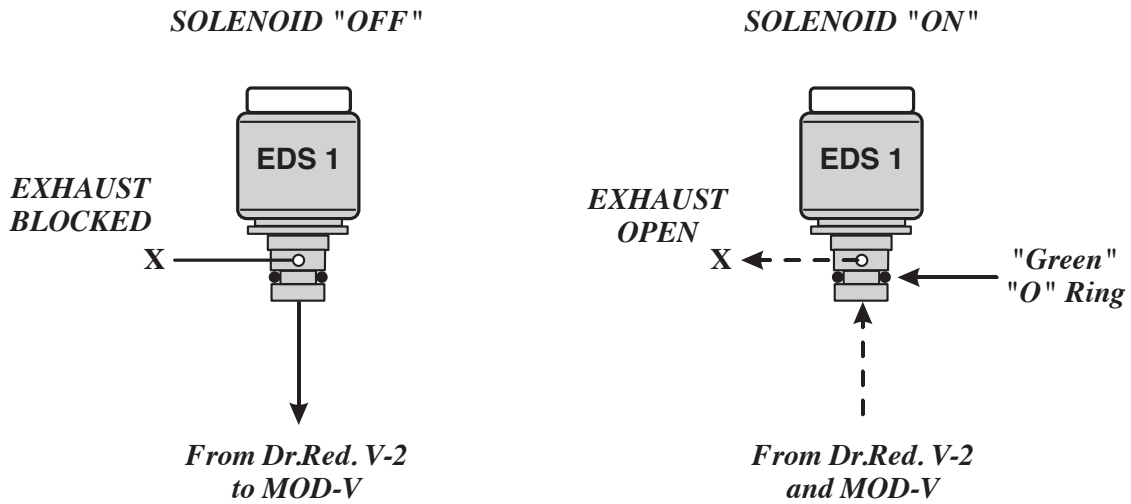

**SUMMARY:**

*When EDS 1 solenoid is "OFF," solenoid reducing pressure, from Dr. Red. V-2, is high to MOD-V valve which creates high line pressure.  
When EDS 1 solenoid is "ON," solenoid reducing pressure, from Dr. Red. V-2, is low to*

Copyright © 2003 ATSG

Figure 101



**TECHNICIANS DIAGNOSTIC GUIDE**  
**BMW, AUDI, PORSCHE**

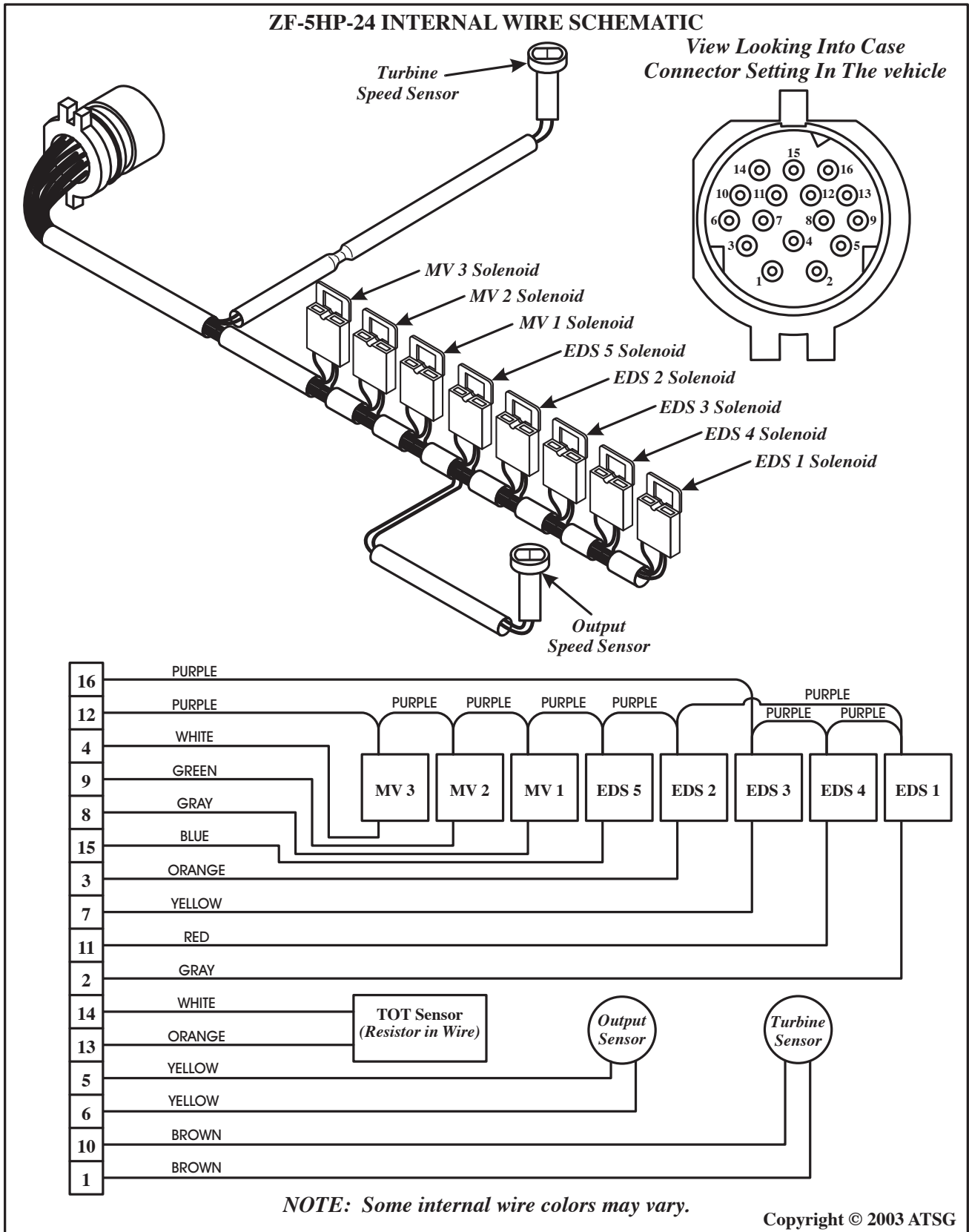

Figure 102



### ZF-5HP-24 SOLENOID APPLICATION CHART

<i>Selector Lever Position</i>	<i>MV 1 Solenoid</i>	<i>MV 2 Solenoid</i>	<i>MV 3 Solenoid</i>	<i>EDS 1 Solenoid</i>	<i>EDS 2 Solenoid</i>	<i>EDS 3 Solenoid</i>	<i>EDS 4 Solenoid</i>	<i>EDS 5 Solenoid</i>	<b>GEAR RATIO</b>
<b>PARK</b>	ON		ON	**	-*	*		-*	
<b>REVERSE</b>		ON	⊗	**	*-	*		*-	<b>4.10:1</b>
<b>NEUTRAL</b>	ON		ON	**	-*	*		-*	
<b>D-1ST</b>	ON			**	*-	*		*-	<b>3.57:1</b>
<b>D-2ND</b>	ON	ON		**		*		*	<b>2.20:1</b>
<b>D-3RD</b>		ON		**		*			<b>1.51:1</b>
<b>D-4TH</b>		ON		**			-*-		<b>1.00:1</b>
<b>D-5TH</b>				**			-*-		<b>0.80:1</b>
<b>D-5TH "TCC"</b>				**			*		<b>0.80:1</b>

### SOLENOID CHART LEGEND

<i>Symbol</i>	<i>Description</i>
ON	<i>MV 1, MV 2 and MV 3 Solenoids are energized by the Electronic Transmission Control unit and have two functions. They are Open or Closed. Energized (On), there is pressure in circuit.</i>
⊗	<i>MV 3 is turned "ON" if reverse is selected at a high vehicle speed, to inhibit reverse engagement.</i>
**	<i>EDS 1 is used for line pressure control only, and operates from 0 to 0.8 amps. When the solenoid is "OFF" (0 amps), pressure is high. EDS 1 pressure is "Lowered" as the solenoid is modulated by the control unit.</i>
*	<i>EDS 2, EDS 3, EDS 4 and EDS 5 Solenoids are also pulse modulated but are exactly the opposite of EDS 1 Solenoid. When these solenoids are "ON" oil pressure in the hydraulic circuit is high, and when they are "OFF" pressure in the hydraulic circuit is low.</i>
-*	<i>Solenoid "OFF" (hydraulic pressure low), then Solenoid "ON" (hydraulic pressure high).</i>
*-	<i>Solenoid "ON" briefly (hydraulic pressure high), then Solenoid "OFF" (hydraulic pressure low). The pressure acts briefly on regulator valves to cushion clutch application.</i>
-*-	<i>EDS 4 Solenoid is used for Torque Converter Clutch apply and release only, and depends on throttle position and vehicle speed as to its application.</i>

Figure 103



**TECHNICIANS DIAGNOSTIC GUIDE  
BMW, AUDI, PORSCHE**

**EDS-5 SOLENOID OPERATION**

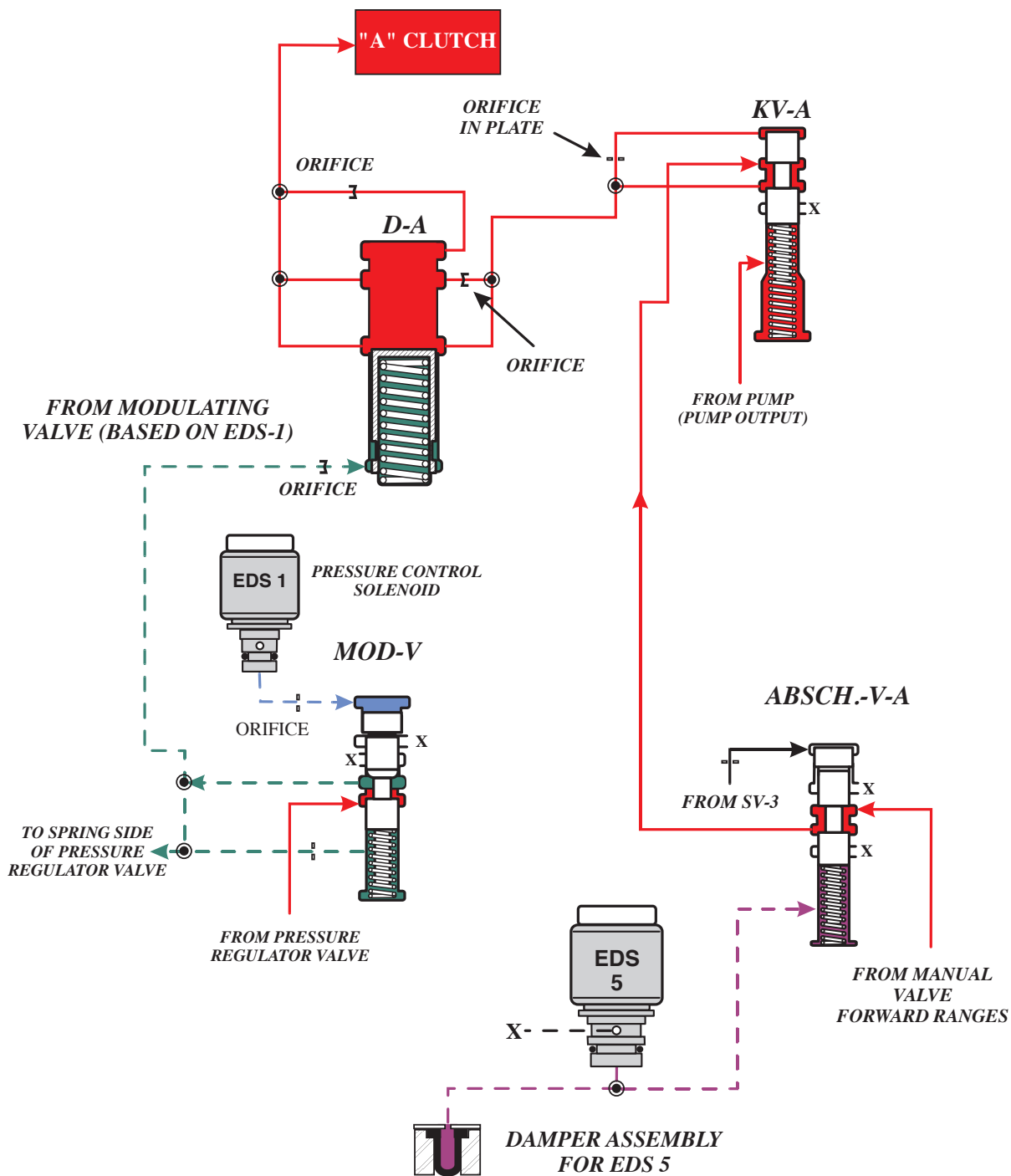

*EDS 5 is used to prevent the ABSCH.-V-A, which is the switch valve for the A clutch, from stroking against its spring. Its use is mainly for forward engagement and a 5-4 downshift.*

Copyright © 2003 ATSG

Figure 104



**TECHNICIANS DIAGNOSTIC GUIDE**  
**BMW, AUDI, PORSCHE**

**SOLENOID AND SENSOR RESISTANCE CHART**

Solenoid	Case Connector Pin Numbers		Resistance In Ohms
	-	+	
MV 1	8 and 12		30 - 34 Ω
MV 2	9 and 12		30 - 34 Ω
MV 3	4 and 12		30 - 34 Ω
EDS 1	2 and 12		5.2 - 6.8 Ω
EDS 2	3 and 12		6.2 - 7.8 Ω
EDS 3	7 and 12		6.2 - 7.8 Ω
EDS 4	11 and 12		6.2 - 7.8 Ω
EDS 5	15 and 12		6.2 - 7.8 Ω
TOT	13 and 14		1000 Ω at 25° C
TSS	1 and 10		292 - 358 Ω
OSS	5 and 6		292 - 358 Ω

*View Looking Into Case  
Connector Setting In The vehicle*

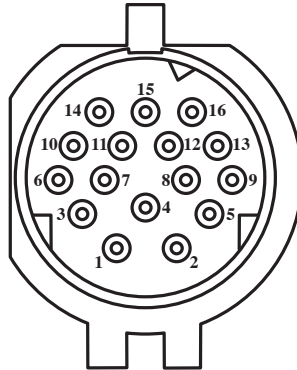

*Electronic Control Unit Connector Pin Identification*

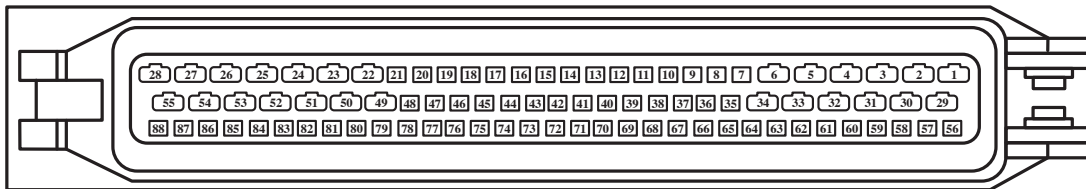

Copyright © 2003 ATSG

Figure 105

**ZF-5HP-24 UPPER VALVE BODY**

*Refer to Figure 119  
on Page 134 for  
Spring Specifications*

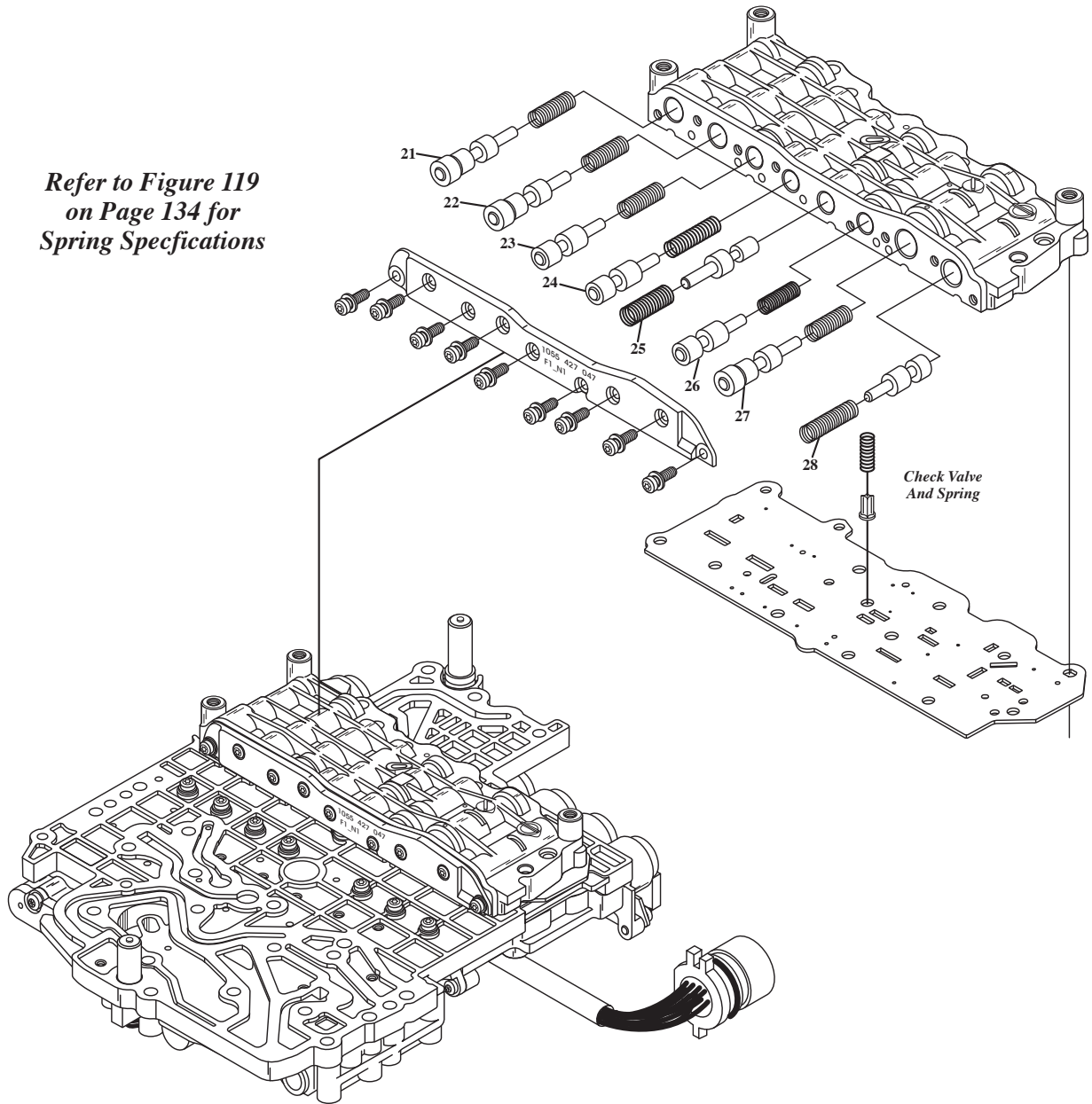

- 21. Clutch Valve "F" Line-Up (KV-F).
- 22. Clutch Valve "E" Line-Up (KV-E).
- 23. Pressure Reducing Valve 1 (DR-V1).
- 24. Pressure Reducing Valve 2 (DR-V2).
- 25. Clutch Valve "B" Line-Up (KV-B).
- 26. Holding Valve "E" Line-Up (HV-E).
- 27. Switch Valve For "A" Clutch (ABSCH-V-A).

Copyright © 2003 ATSG

Figure 106



**TECHNICIANS DIAGNOSTIC GUIDE  
BMW, AUDI, PORSCHE**

**ZF-5HP-24 LOWER FRONT VALVE BODY**

*Refer to Figure 119  
on Page 134 for  
Spring Specifications*

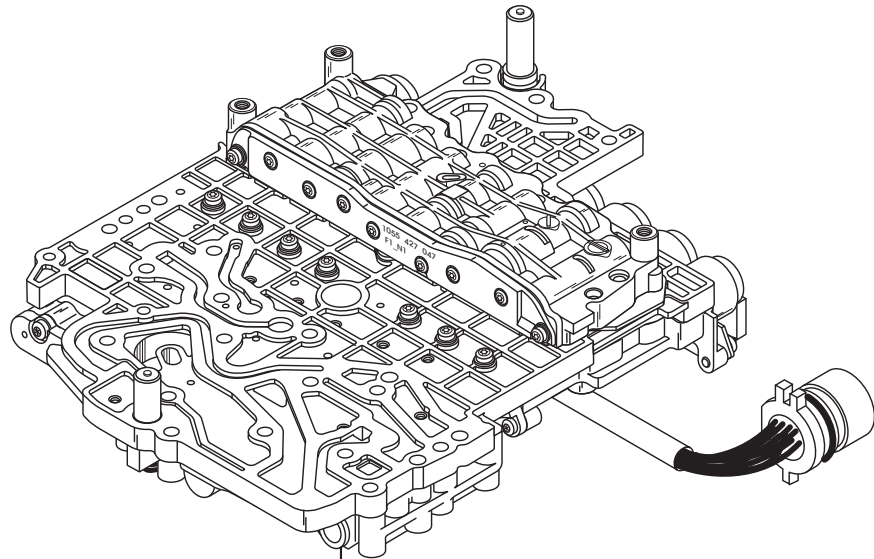

- 9. Manual Shift Valve (W-S).
- 10. Converter Clutch Apply Oil Control Valve (WK-V).
- 11. Converter Clutch Release Oil Control Valve (WD-V).
- 12. Main Pressure Regulator Valve Line-Up (HD-V).
- 13. Lubrication Valve (SCHM-V)
- 14. Modulating Valve Line-Up (MOD-V).
- 15. Holding Valve For "B" Clutch (HV-B).
- 16. Accumulator Valve For EDS 2 Solenoid (D-2).
- 17. Holding Valve For "D" Clutch (HV-D).
- 18. Accumulator Valve For EDS 4 Solenoid (D-4).
- 19. Accumulator Valve For EDS 3 Solenoid (D-3).

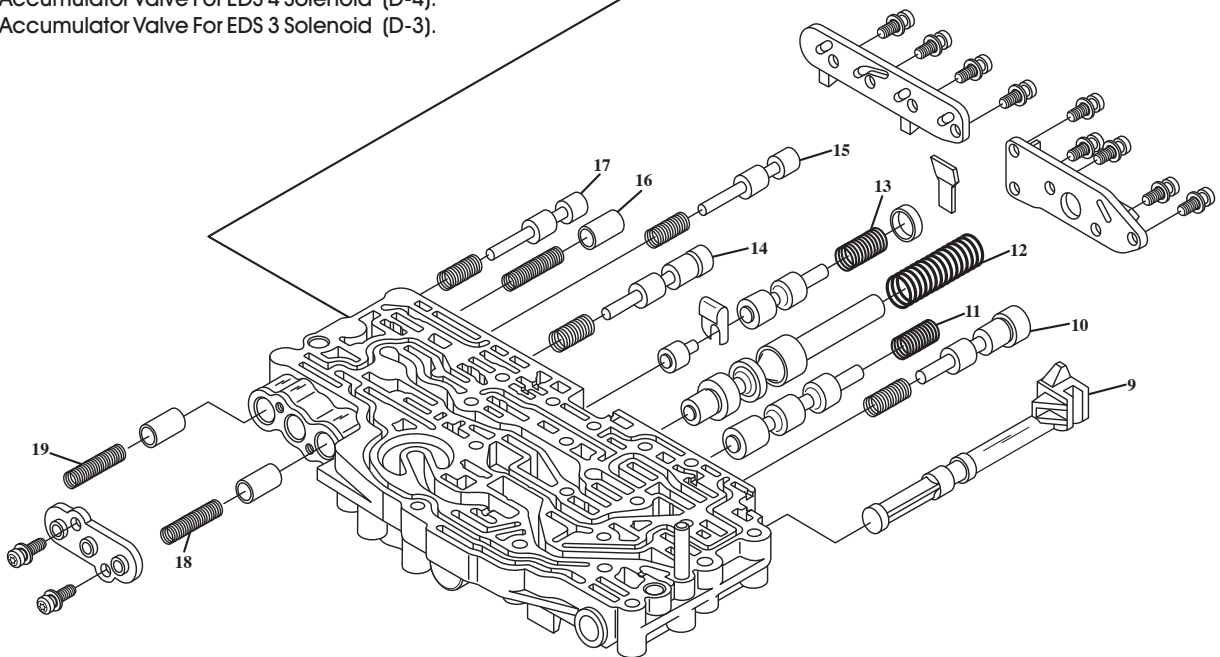

Copyright © 2003 ATSG

Figure 107



**TECHNICIANS DIAGNOSTIC GUIDE  
BMW, AUDI, PORSCHE**

**ZF-5HP-24 LOWER REAR VALVE BODY**

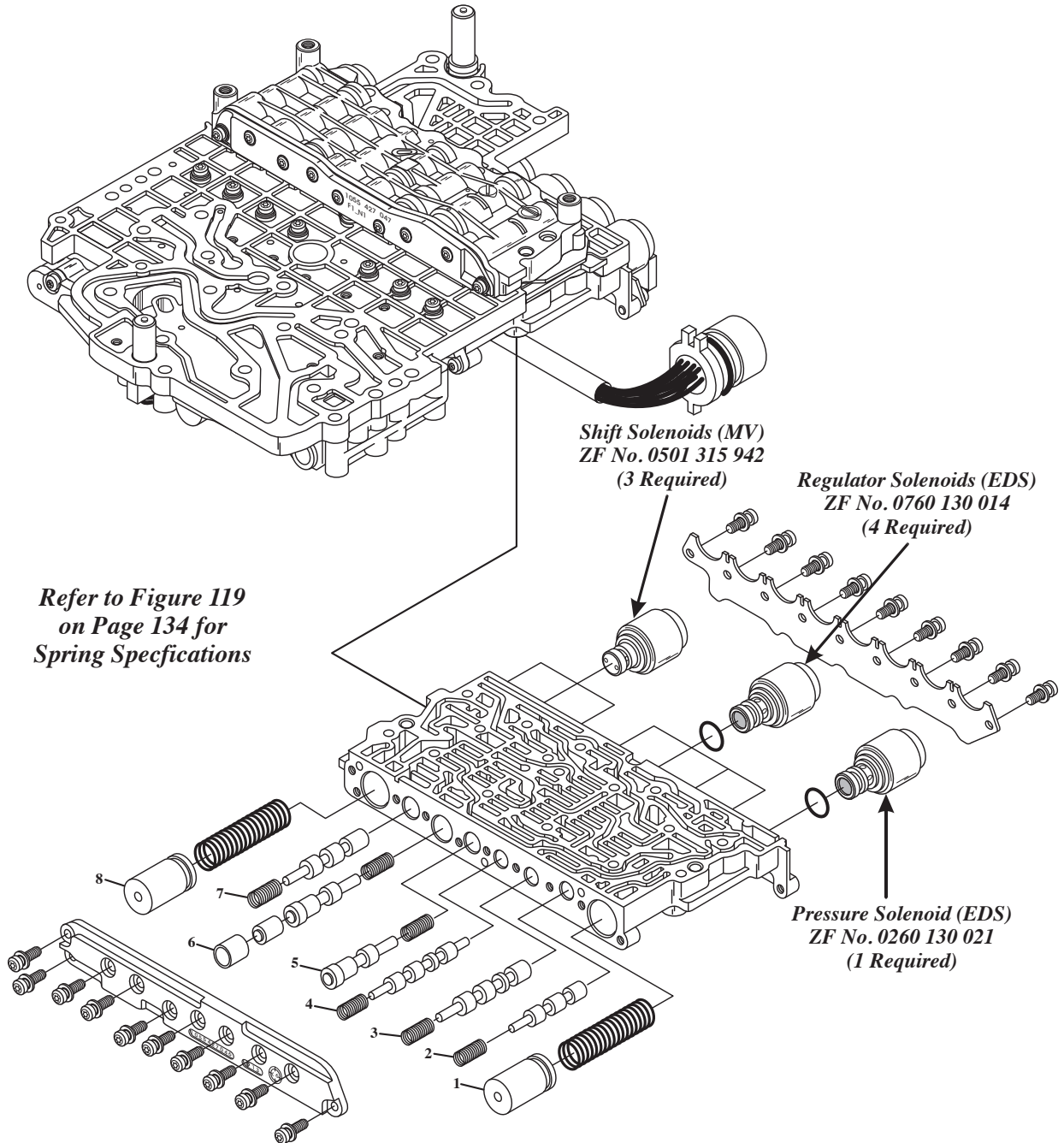

- 1. "A" Clutch Accumulator Line-Up (D-A).
- 2. Shift Valve Number 1 (SV-1).
- 3. Shift Valve Number 2 (SV-2).
- 4. Shift Valve Number 3 (SV-3).
- 5. Switch Valve For "D" Clutch (ABSCH-V-D).
- 6. Clutch Valve "D" Line-Up (KV-D).
- 7. Reverse Gear Valve Line-Up (RG-V).
- 8.

Copyright © 2003 ATSG

Figure 108



# TECHNICIANS DIAGNOSTIC GUIDE BMW, AUDI, PORSCHE

## ZF 5HP-24 UPPER VALVE BODY

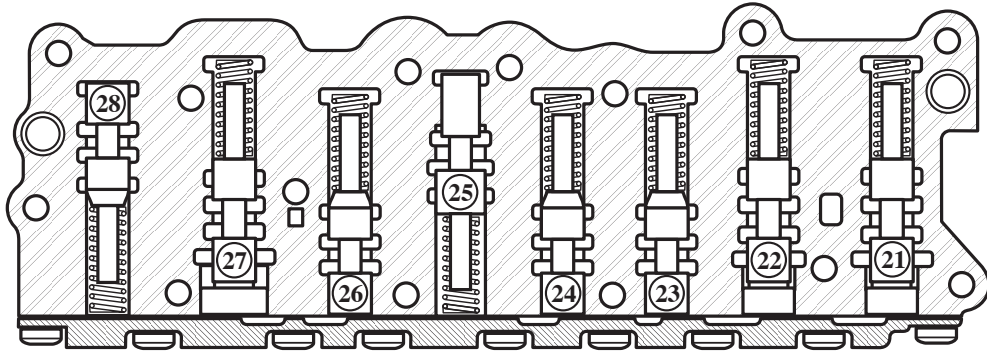

- 21. Clutch Valve "F" Line-Up (KV-F).
- 22. Clutch Valve "E" Line-Up KV-E).
- 23. Pressure Reducing Valve 1 (DR-V1).
- 24. Pressure Reducing Valve 2 (DR-V2).
- 25. Clutch Valve "B" Line-Up (KV-B).
- 26. Holding Valve "E" Line-Up (HV-E).
- 27. Switch Valve For "A" Clutch (ABSCH-V-A).

*Refer to Figure 119  
on Page 134 for  
Spring Specifications*

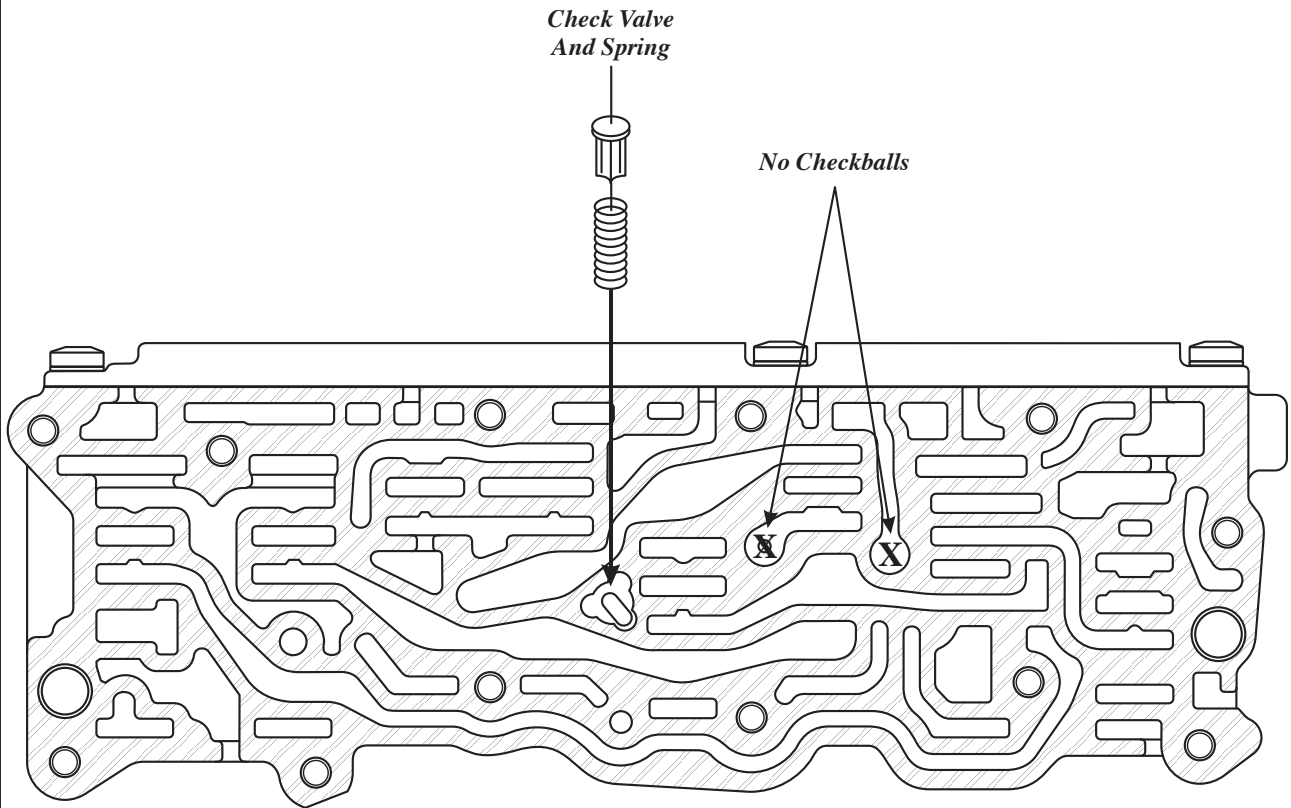

Copyright © 2003 ATSG

Figure 109





**TECHNICIANS DIAGNOSTIC GUIDE**  
**BMW, AUDI, PORSCHE**

**ZF 5HP-24 LOWER FRONT VALVE BODY**

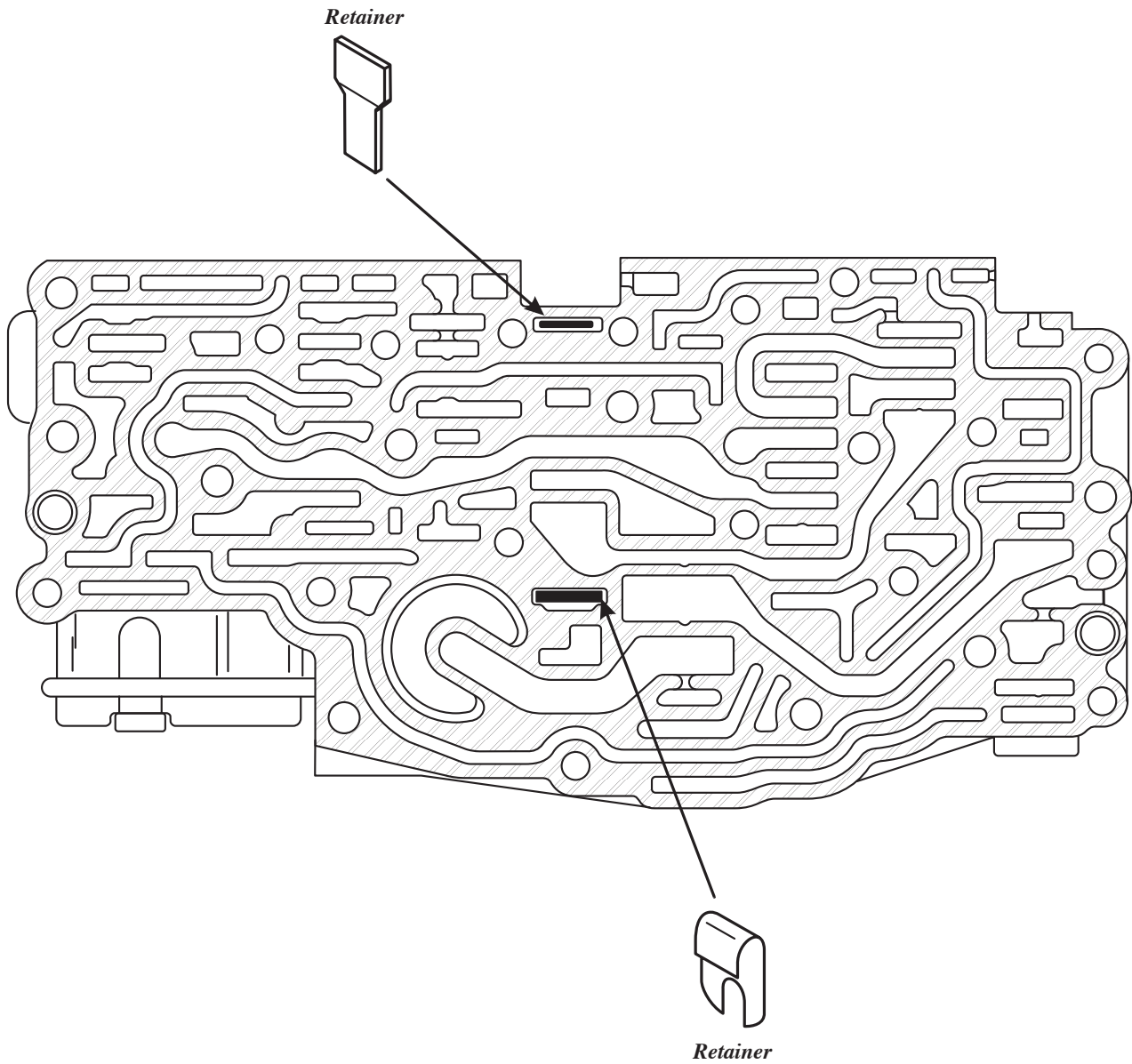

Copyright © 2003 ATSG

Figure 110





**TECHNICIANS DIAGNOSTIC GUIDE**  
**BMW, AUDI, PORSCHE**

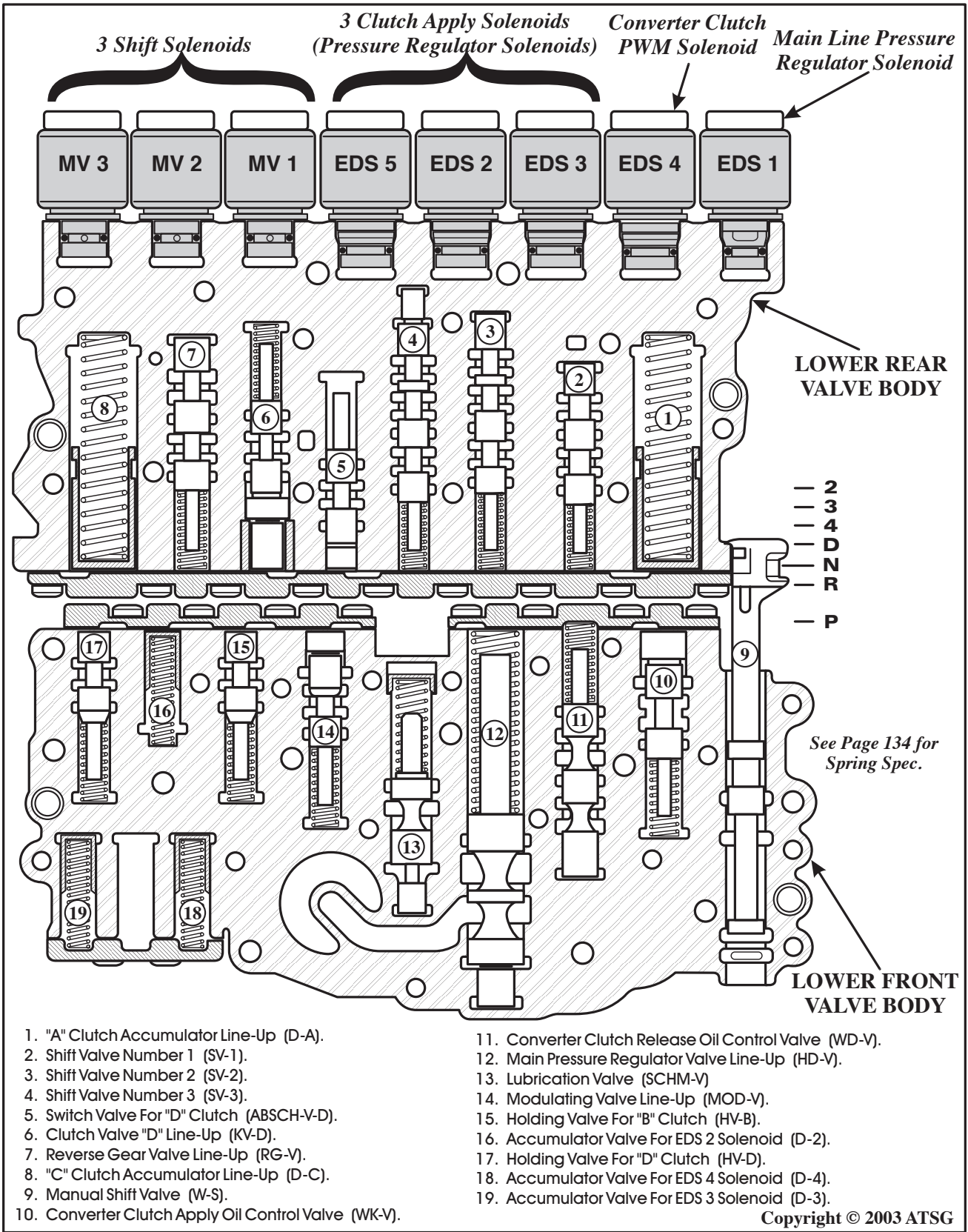

Figure 111

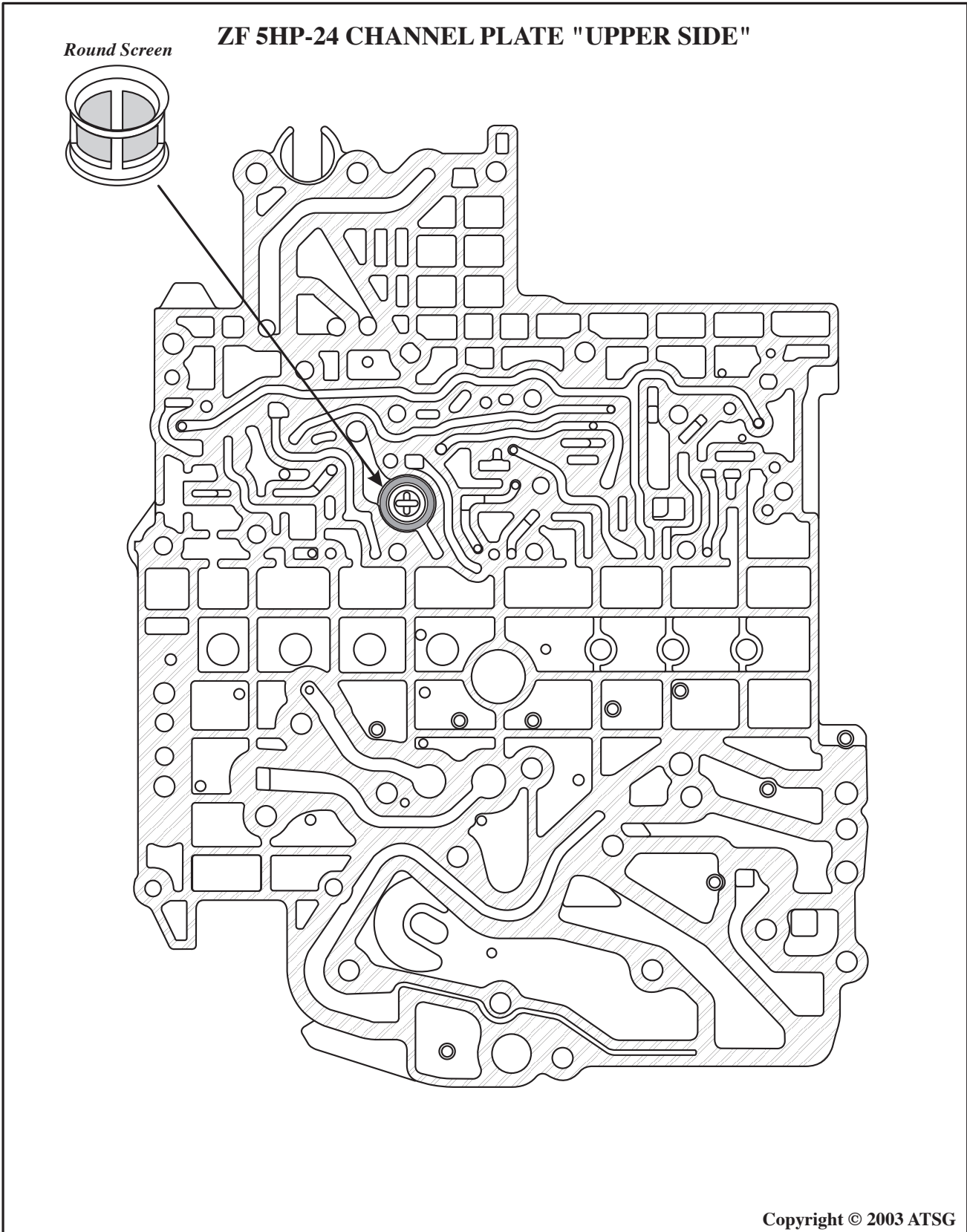

Figure 112



# TECHNICIANS DIAGNOSTIC GUIDE

## BMW, AUDI, PORSCHE

### ZF 5HP-24 CHANNEL PLATE "LOWER SIDE"

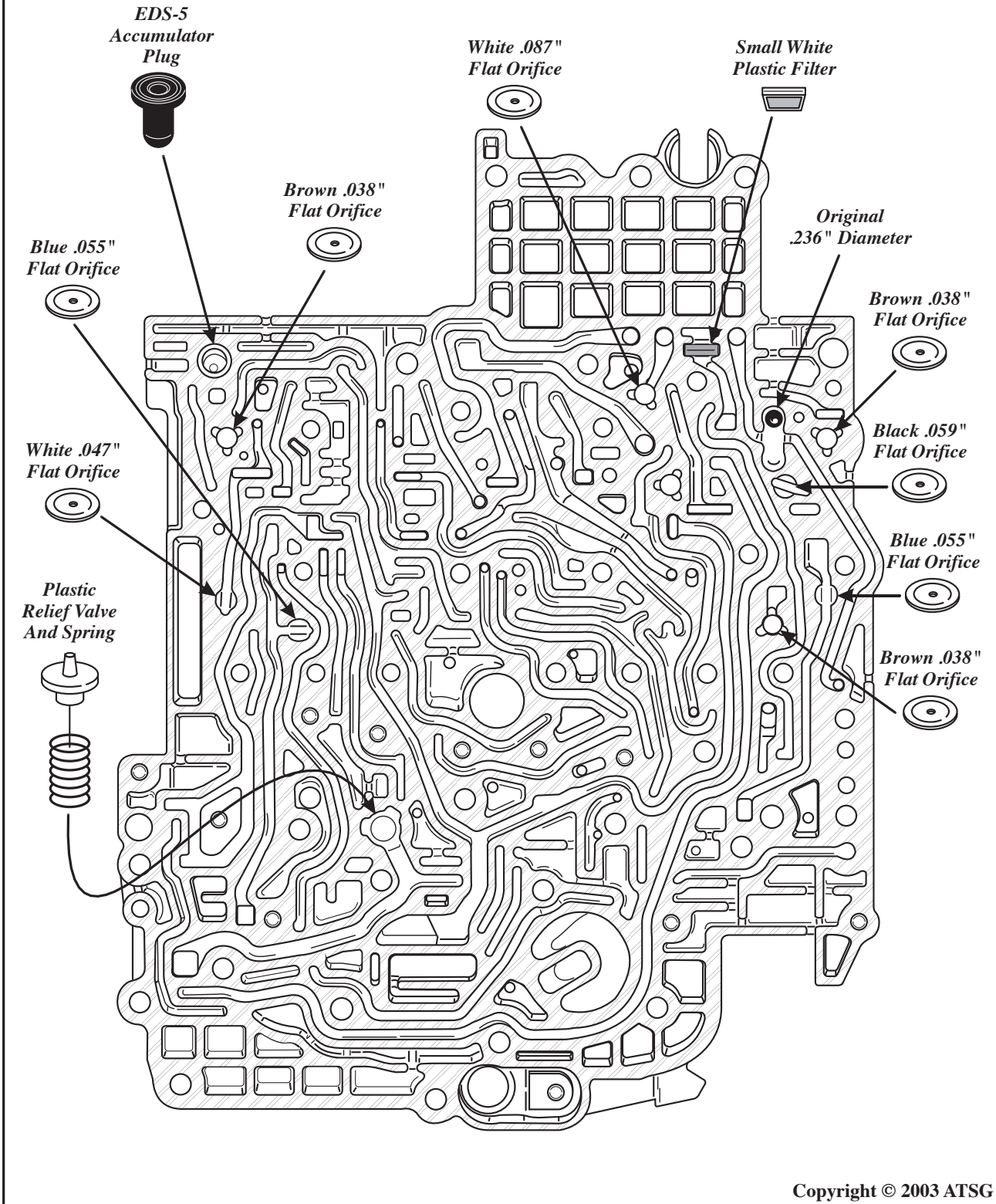

Copyright © 2003 ATSG

Figure 113



**TECHNICIANS DIAGNOSTIC GUIDE**  
**BMW, AUDI, PORSCHE**

**PRESSURE TAP LOCATIONS AND IDENTIFICATION**

*Jaguar Model Shown*

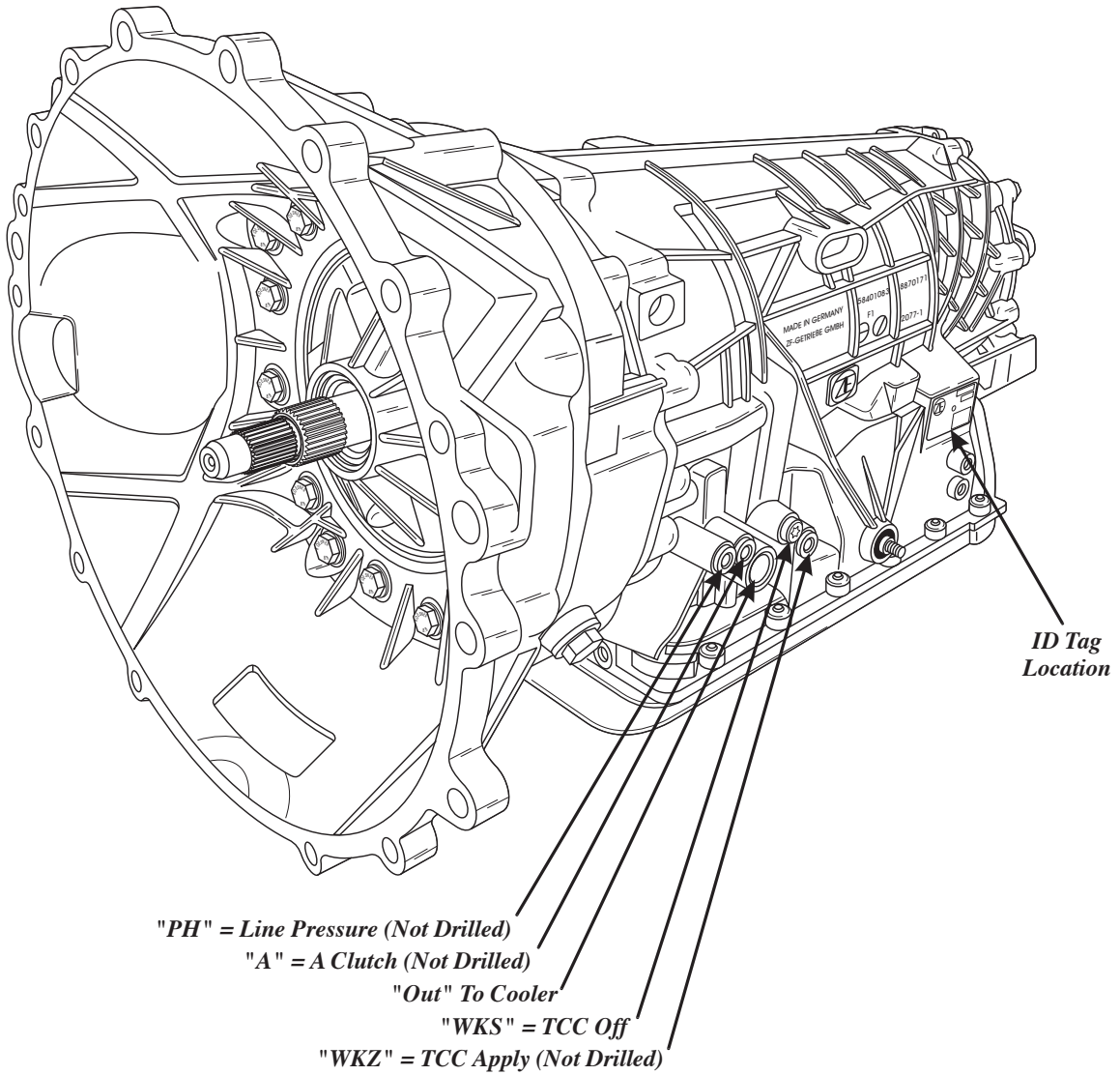

Copyright © 2003 ATSG

Figure 114

**PUMP VOLUME CONTROL  
VALVE LOCATION**

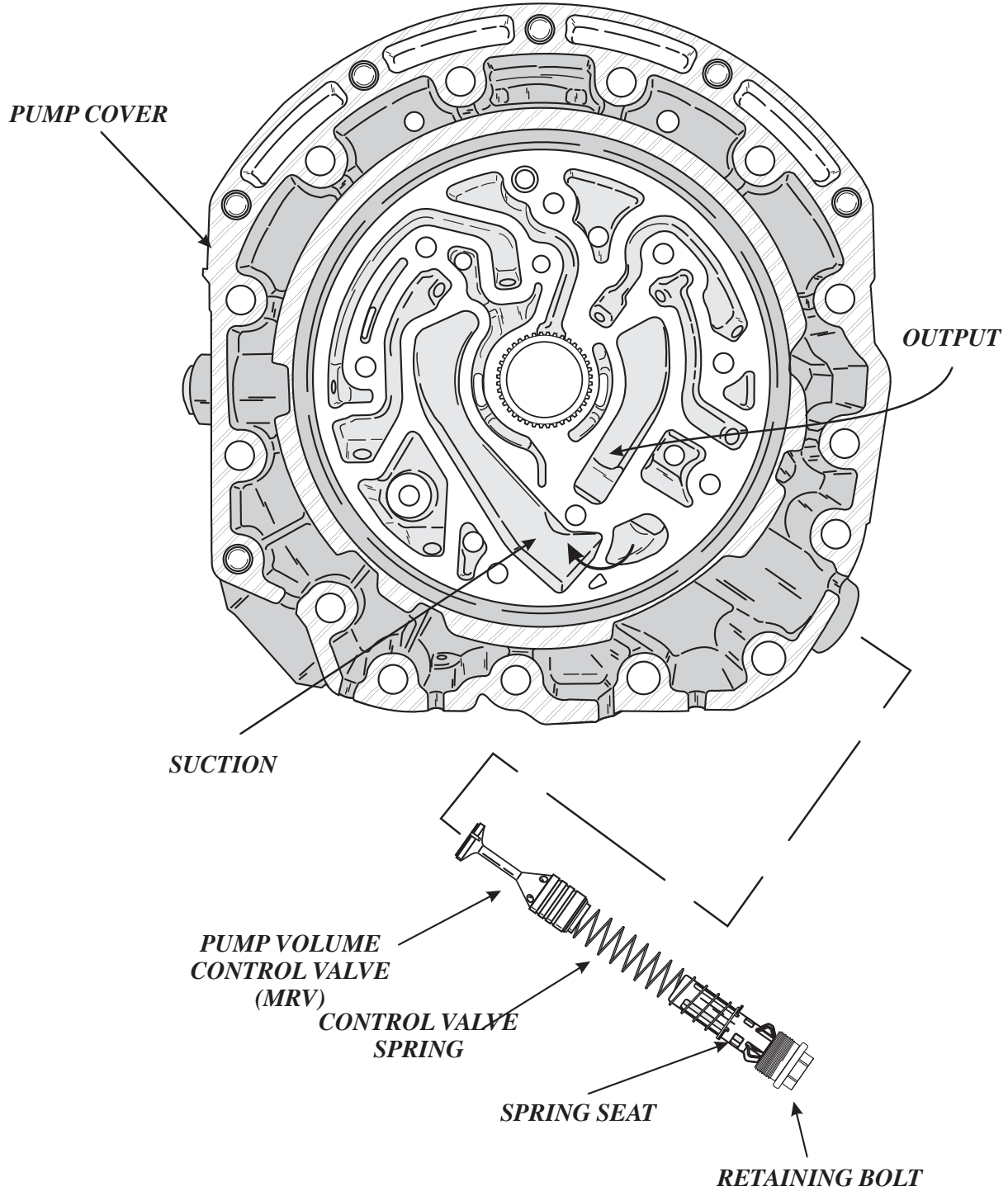

Copyright © 2003 ATSG

Figure 115



**PUMP VOLUME CONTROL  
VALVE OPERATION**

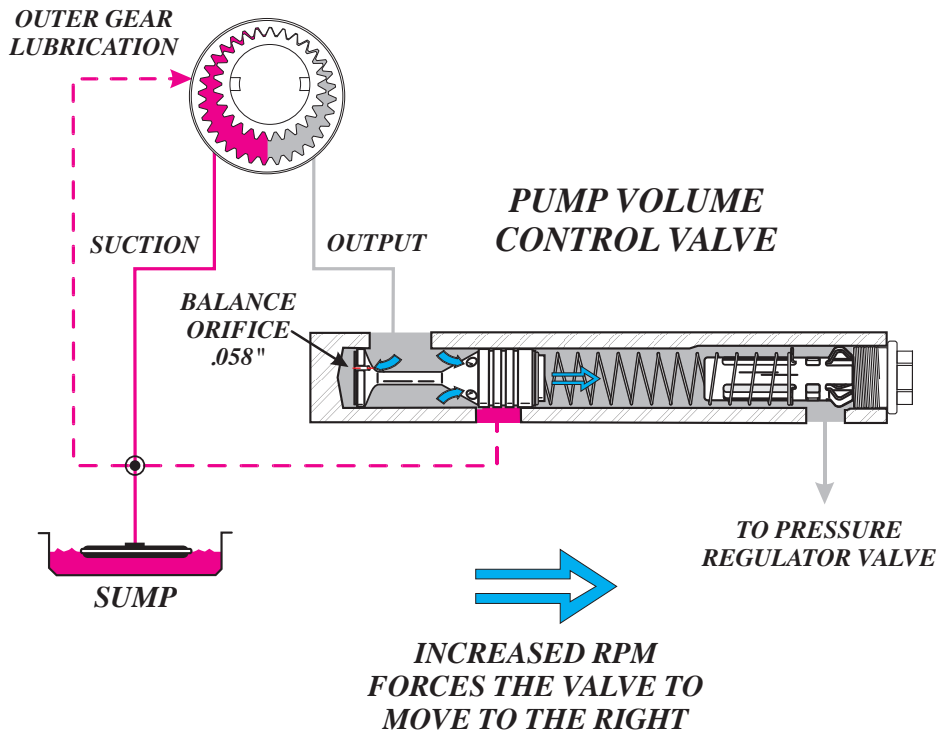

*The Pump Volume Control Valve regulates the amount of oil volume to the Pressure Regulator Valve. As engine rpm. increases, pump output increases and forces the Pump Volume Control Valve to move to the right. This allows excess pump output to return to the sump, and a consistent amount of volume to be sent to the Pressure Regulator Valve. The Pump Control Valve maintains 45 to 48 gallons per minute from 2000 to 6000 rpm.*

Figure 116



**TECHNICIANS DIAGNOSTIC GUIDE**  
**BMW, AUDI, PORSCHE**

**ZF 5HP-24 PUMP COVER REAR VIEW**

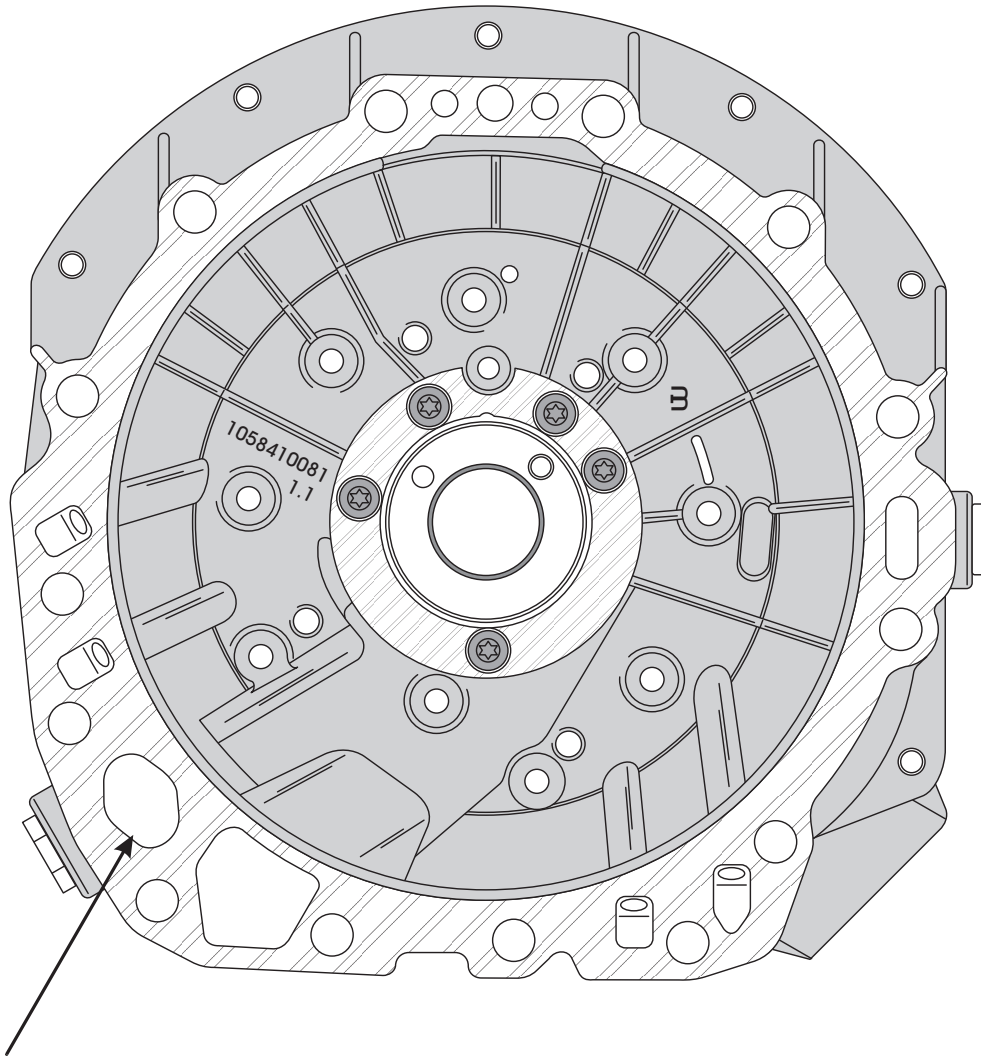

*Output to Pressure  
Regulator Valve*

Copyright © 2003 ATSG

Figure 117



**TECHNICIANS DIAGNOSTIC GUIDE  
BMW, AUDI, PORSCHE**

**PUMP AND  
PUMP PLATE**

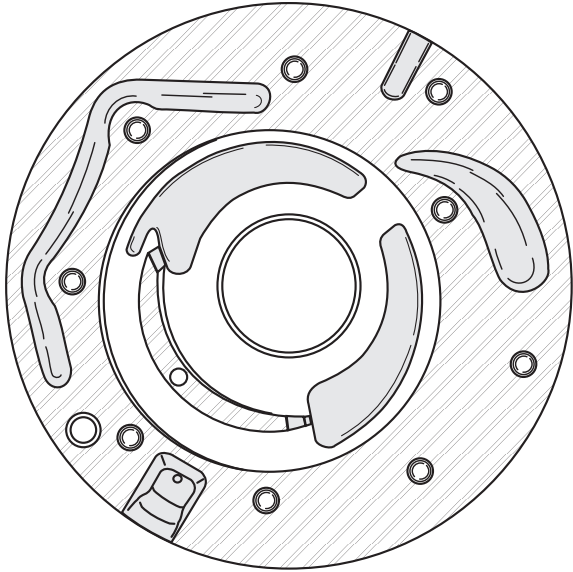

**PUMP BODY**

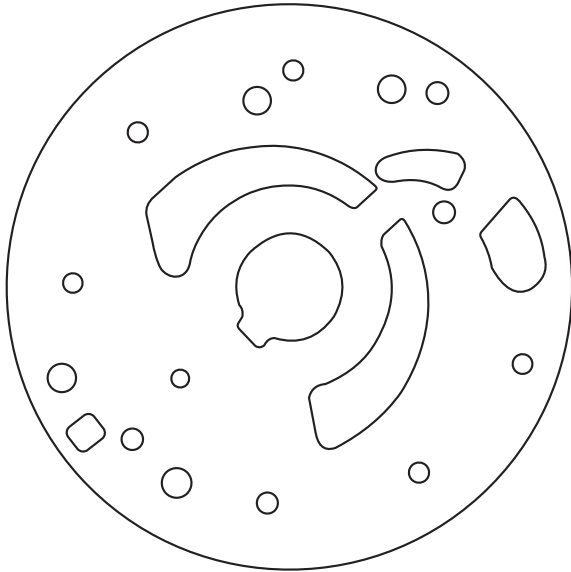

**PUMP PLATE**

**OUTER PUMP  
GEAR LUBRICATION**

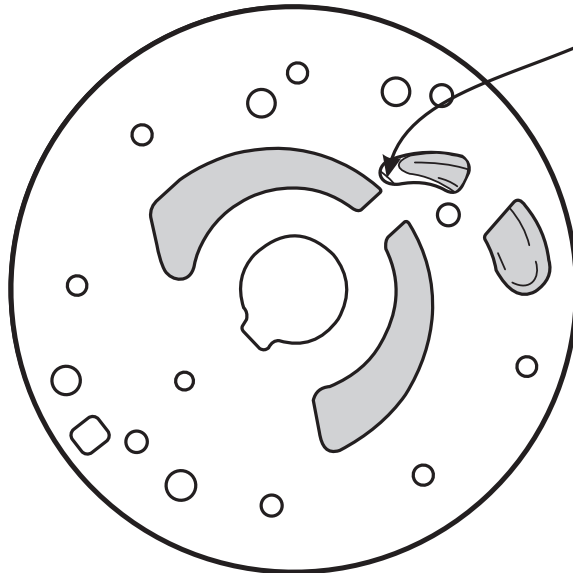

**PUMP PLATE INSTALLED  
ON PUMP BODY**

Copyright © 2003 ATSG

Figure 118





**TECHNICIANS DIAGNOSTIC GUIDE  
BMW, AUDI, PORSCHE**

**ZF 5HP-24 VALVE BODY SPRING SPECIFICATIONS**

**UPPER VALVE BODY**

- |  |  |  |
|--|--|--|
| 21. Clutch Valve "F" (KV-F)<br>Free Length = 1.400"<br>Wire Diameter = .031"<br>Outside Diameter = .365"         | 24. Pressure Reducing Valve (DR-V2)<br>Free Length = 1.942"<br>Wire Diameter = .045"<br>Outside Diameter = .370" | 27. A Clutch Swit Valve (ABSCH.V-A)<br>Free Length = 1.455"<br>Wire Diameter = .028"<br>Outside Diameter = .365" |
| 22. Clutch Valve "E" (KV-E)<br>Free Length = 1.551"<br>Wire Diameter = .031"<br>Outside Diameter = .365"         | 25. Clutch Valve "B" (KV-B)<br>Free Length = 1.710"<br>Wire Diameter = .042"<br>Outside Diameter = .420"         | 28. Clutch Valve "A" (KV-A)<br>Free Length = 1.830"<br>Wire Diameter = .028"<br>Outside Diameter = .316"         |
| 23. Pressure Reducing Valve (DR-V1)<br>Free Length = 1.685"<br>Wire Diameter = .042"<br>Outside Diameter = .370" | 26. Holding Valve "E" (KV-E)<br>Free Length = 1.685"<br>Wire Diameter = .042"<br>Outside Diameter = .372"        |  |

*These spring locations shown on Page 121.*

**LOWER "FRONT" VALVE BODY**

- |   |   |   |
|---|---|---|
| 10. TCC Apply Control Valve (WK-V)<br>Free Length = 1.952"<br>Wire Diameter = .042"<br>Outside Diameter = .370"   | 14. Modulating Valve (MOD-V)<br>Free Length = 1.493"<br>Wire Diameter = .031"<br>Outside Diameter = .365"         | 18. EDS 4, Accumulator Valve (D-4)<br>Free Length = 1.560"<br>Wire Diameter = .042"<br>Outside Diameter = .322" |
| 11. TCC Release Control Valve (WD-V)<br>Free Length = 2.052"<br>Wire Diameter = .034"<br>Outside Diameter = .438" | 15. Holding Valve, "B" Clutch (HV-B)<br>Free Length = 1.414"<br>Wire Diameter = .031"<br>Outside Diameter = .365" | 19. EDS 3, Accumulator Valve (D-3)<br>Free Length = 1.560"<br>Wire Diameter = .042"<br>Outside Diameter = .322" |
| 12. Pressure Regulator Valve (HD-V)<br>Free Length = 3.780"<br>Wire Diameter = .087"<br>Outside Diameter = .686"  | 16. EDS 2, Accumulator Valve (D-2)<br>Free Length = 1.565"<br>Wire Diameter = .042"<br>Outside Diameter = .322"   |   |
| 13. Lubrication Valve (SCHM.-V)<br>Free Length = 1.710"<br>Wire Diameter = .048"<br>Outside Diameter = .485"      | 17. Holding Valve, "D" Clutch (HV-B)<br>Free Length = 1.681"<br>Wire Diameter = .042"<br>Outside Diameter = .375" |   |

*These spring locations shown on Page 122.*

**LOWER REAR VALVE BODY**

- |  |   |  |
|--|---|--|
| 1. "A" Clutch Accumulator (D-A)<br>Free Length = 3.067"<br>Wire Diameter = .066"<br>Outside Diameter = .595" | 4. Shift Valve Number 3 (SV-3)<br>Free Length = 1.640"<br>Wire Diameter = .031"<br>Outside Diameter = .366"         | 7. Reverse Gear Valve (RG-V)<br>Free Length = 1.800"<br>Wire Diameter = .038"<br>Outside Diameter = .435"    |
| 2. Shift Valve Number 1 (SV-1)<br>Free Length = 1.755"<br>Wire Diameter = .031"<br>Outside Diameter = .367"  | 5. Switch Valve "D" Clutch (ABSCH.V-D)<br>Free Length = 1.396"<br>Wire Diameter = .039"<br>Outside Diameter = .300" | 8. "C" Clutch Accumulator (D-C)<br>Free Length = 3.067"<br>Wire Diameter = .066"<br>Outside Diameter = .595" |
| 3. Shift Valve Number 2 (SV-2)<br>Free Length = 1.770"<br>Wire Diameter = .031"<br>Outside Diameter = .367"  | 6. Clutch Valve "D" Line-Up (KV-D)<br>Free Length = 1.800"<br>Wire Diameter = .031"<br>Outside Diameter = .360"     |  |

*These spring locations shown on Page 123.*

Copyright © 2003 ATSG

Figure 119