

**ECAS**

For Passenger Cars and Light  
Commercial Vehicles



**WABCO**

# Electronically Controlled Air Suspension

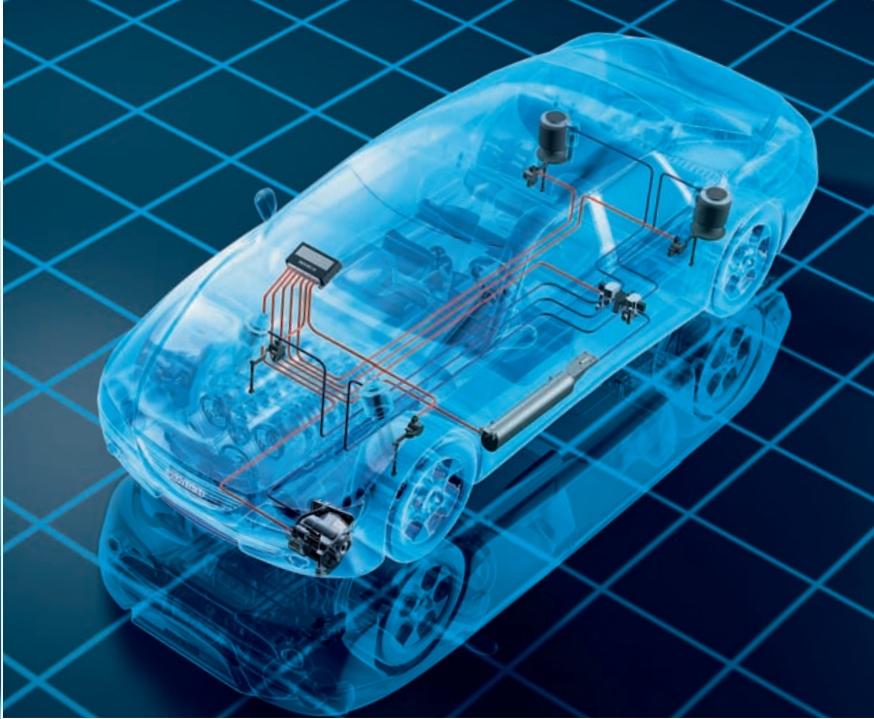

The luxury car, SUV and light commercial vehicle sectors increasingly demand air suspension systems and shock absorber controls. Air suspension and the responsiveness of continuously variable shock absorber control provide increased driving comfort and safety on various road surfaces and in most driving situations.

Air suspension provides excellent ride comfort even when vehicle loads vary. WABCO's ECAS achieves this by keeping vehicle height constant. In addition, automatic side-to-side adjustment is provided.

## Features

- Height and dynamics control of the vehicle body
- Adjusted damper characteristics depending on driving situations
- Speed-dependent lowering for reduced fuel consumption and enhanced handling
- Entry facility for easy access and cargo loading
- Better appearance while stationary
- Increased off-road clearance
- Lowers on demand for easy trailer-hook-up

## Modular design

A modular concept for partially and fully air suspended vehicles has been developed. This concept is based on 12-volt components such as:

- Compressors
- Solenoid valves
- Air reservoirs
- Height, acceleration and pressure sensors
- Electronic control units

For this purpose WABCO has developed a family of compressors. Depending on the type of the air suspension system application, three compressors with different performance ratings are available.

A high level of integration for additional components such as electronic control units, solenoid valves, sensors, wiring, relay, etc. permits complete air delivery systems to be customized to client's needs.

#### Four-corner air suspension with air reservoir and active shock absorber control (High Power Compressor)

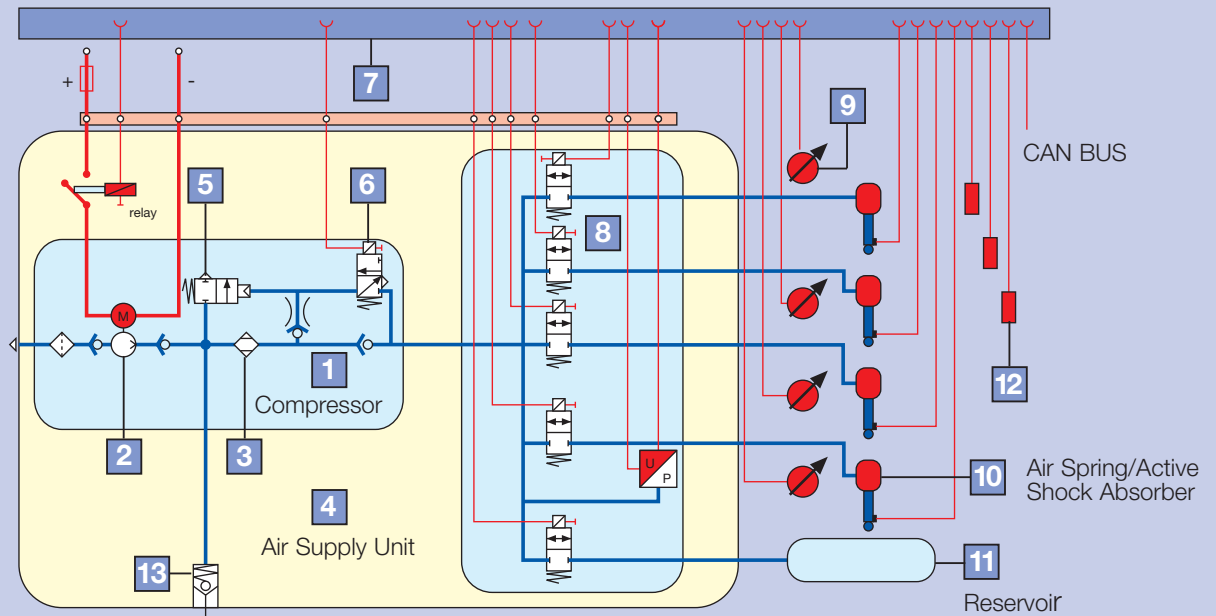

## Operation

When the ignition is switched on, or when the vehicle's door is opened before ignition, the control system is activated. The height sensor (9) uses the induction principle to constantly monitor the distance between the vehicle's axle and its chassis.

When the vehicle is being loaded/unloaded, or lowered due to driver command or vehicle speed, the electronic readings of the height sensor monitor the change. This is picked up by the electronic control unit (ECU) (7) and compared to the stored reference values.

The ECU either activates the electric motor of the compressor (2) or the exhaust solenoid valve (6). Simultaneously, this also requires the 5 x 2/2 solenoid valve block (8) to be actuated, to maintain the required level. The corner solenoid valves are subject to stringent leakage requirements to maintain the vehicle's height even without system operation.

When the vehicle is being loaded, the compressor (2) delivers air into the four air suspension bellows, until the normal level has once again been reached. For additional air delivery or rapid response, the reservoir solenoid valve is opened and air flows directly from the reservoir. When the vehicle is being unloaded, the 5 x 2/2 solenoid valve block (8) is activated resulting in air flow from the air suspension bellows being removed via the solenoid valve (6) of the air dryer (3) in the compressor, via the relay valve (5), and then air is exhausted to atmosphere. To reach a higher exhaust performance for a quicker lowering of off-road vehicles, WABCO developed the "quick release" air dryer concept.

Any dynamic air spring movement while the vehicle is in motion is ignored and does not cause the control system to respond.

## Lowering and raising the vehicle's body

At the push of a button, the vehicle can be raised or lowered to different levels while stationary, to facilitate loading or unloading.

For this purpose, a remote control unit is also available as an optional extra. This permits the vehicle level to be altered as desired from outside the vehicle.

## Active shock absorber control

A combination of ECU leveling function with an active shock absorber control enhances ride comfort in most driving conditions, enabled by monitoring the acceleration sensor (12) information. This integration offers synergies by using the same sensors for both level and shock absorber control.

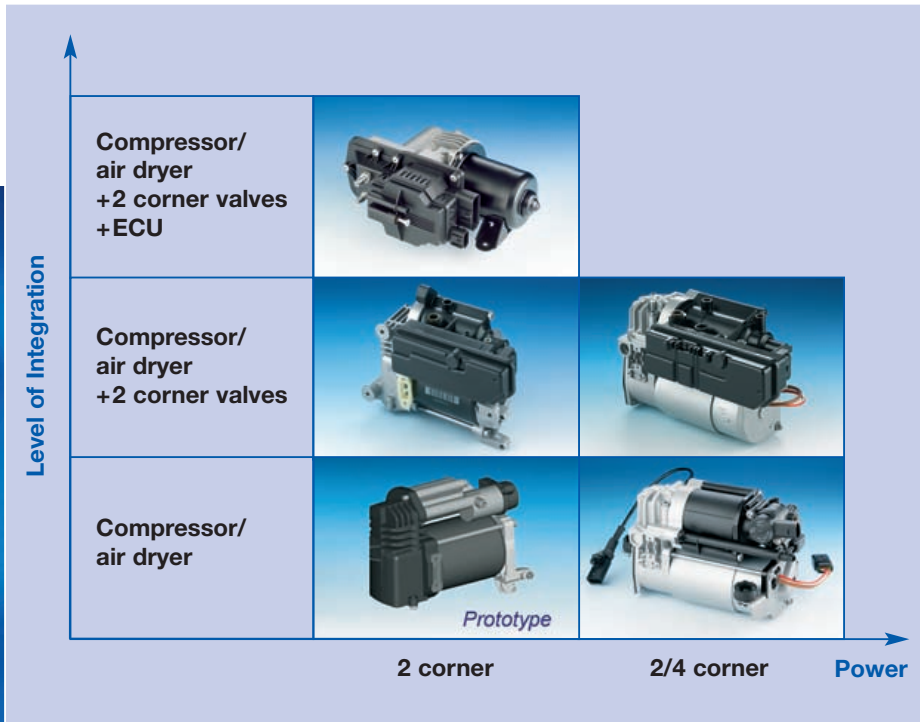

7 ECU



8 Solenoid valve with pressure sensor

### Inflator option

The compressor can also be used as an ancillary inflator for vehicle and bicycle tires as well as small air inflated devices, e.g. beach ball. The inflator control (13) consists of an instant switch for activating the compressor; an LED in the switch indicates that the compressor is running. Air pressure is then available from the schrader valve. In this case, the air does not pass through the air dryer.



10 Air spring



11 Reservoir

### Additional functions

The four-corner air suspension shown is a modular design. Rear axle air suspension systems can be achieved by the same principle, merely by removing the components for the front axle.

In order to ensure the continued availability of compressed air at all times, especially for off-road vehicles, an air reservoir (11) may be used.



13 Inflator control

# Modular design

Rear axle air suspension (Low Power Compressor)

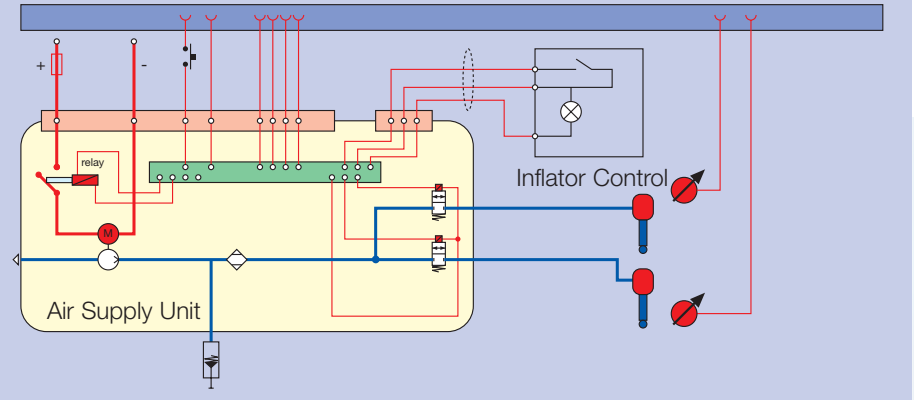

Rear axle air suspension (Medium Power Compressor)

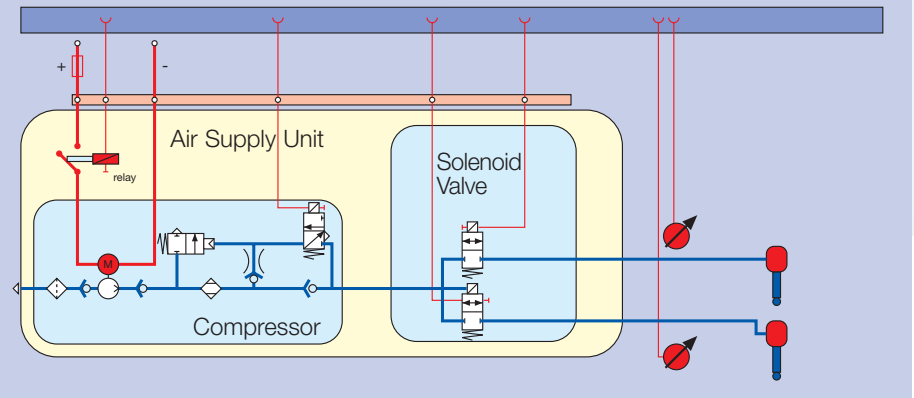

Four-corner air suspension with air reservoir and active shock absorber control (High Power Compressor)

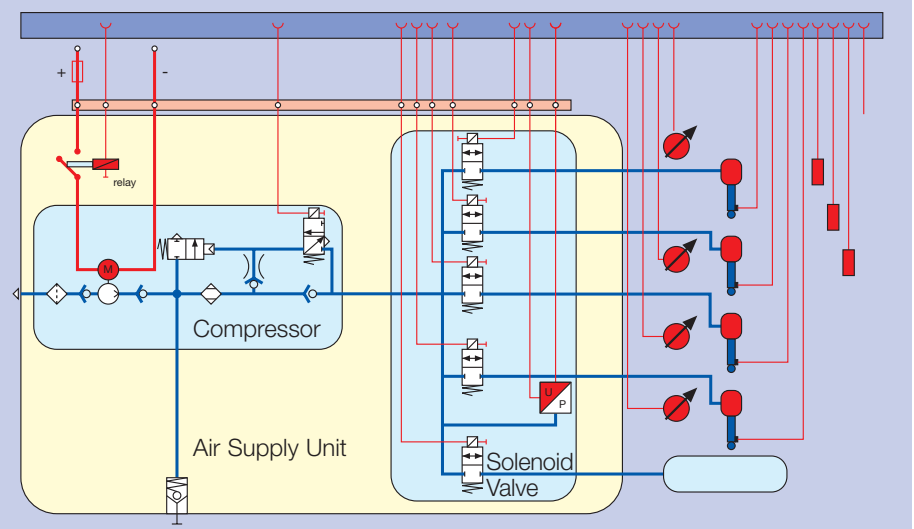



WABCO Vehicle Control Systems is one of the world's leading providers of electronic braking, stability, suspension and transmission control systems for heavy duty commercial vehicles. WABCO products are also increasingly used in luxury cars and sport utility vehicles (SUVs). Customers include the world's leading commercial truck, trailer, bus and passenger car manufacturers. Founded in the U.S. in 1869 as Westinghouse Air Brake Company, WABCO was

acquired by American Standard in 1968 and spun off in 2007. Headquartered in Brussels, Belgium, the business today employs more than 7,700 people in 31 countries worldwide. In 2007, total sales were \$2.4 billion. WABCO is a publicly traded company and is listed on the New York Stock Exchange with the stock symbol WBC.

**Website: [www.wabco-auto.com](http://www.wabco-auto.com)**

