

# FOURTITUDE

AUDI :: LAMBORGHINI :: SEAT :: AUTO UNION

4

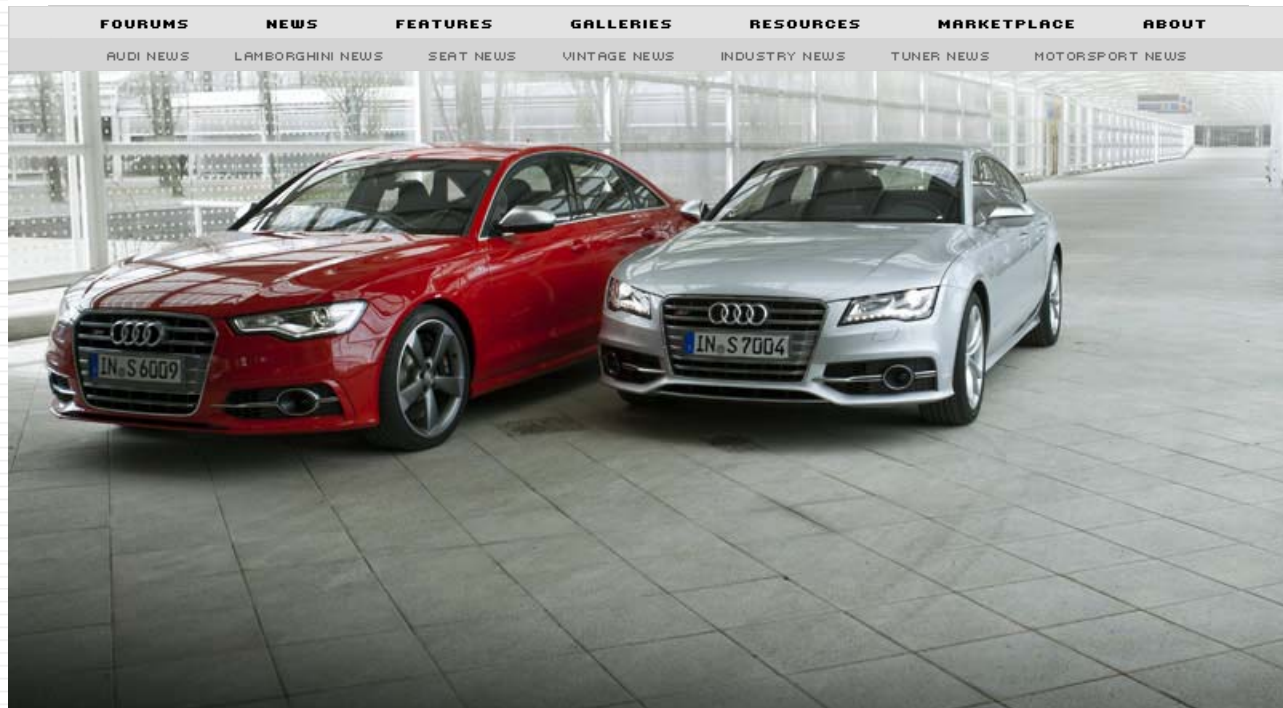

## In Detail: Audi S6, S6 Avant and S7

The newest S models are powerful but elegant sporty cars. They are powered by a newly designed 4.0 TFSI engine, which provides 309 kW (420 hp), yet respectively averages just 9.6 or 9.7 liters of fuel per 100 km (24.50 or 24.25 US mpg) – thanks in part to new cylinder on demand technology. A sophisticated chassis, lightweight bodies and a refined interior complete the profile of these perfect new Audi athletes.

Apr 22, 2012

source: Audi AG



### THE NEW S MODELS BY AUDI - THE LATEST IN STATE OF THE ART

Strong performance, superb dynamics, elegant understatement and everyday practicality: the new S models by Audi combine all of these characteristics with the latest in state of the art. Its V8 engine, the 4.0 TFSI, provides 309 kW (420 hp) yet consumes just 9.6 or 9.7 liters of fuel per 100 km (24.50 or 24.25 US mpg). The cylinder on demand system, which switches off four of the eight cylinders in many driving situations, contributes significantly to this efficiency.

The new S models are sports cars for everyday life. Their twin-turbo V8 delivers 309 kW (420 hp) from a displacement of four liters while transmitting 550 Nm (405.66 lb-ft) of torque between 1,400 and 5,200 rpm. The 4.0 TFSI reacts instantaneously because the approach concerning cylinder heads – the inlet side is outside and the exhaust-gas side is inside – allows for short gas-travel paths with minimal friction losses. Two twin-scroll turbochargers ensure that considerable torque is generated faster than otherwise.

The Audi S6 accelerates from zero to 100 km/h (62.14 mph) in 4.6 seconds; the S6 Avant and the S7 Sportback each need just one-tenth of a second longer. The S6 and the S7 Sportback each averages 9.6 liters of fuel per 100 km (24.50 US mpg), while the S6 Avant consumes 9.7 l/100 km (24.25 US mpg).

The all-new cylinder on demand system, which switches off four of the eight cylinders during part-load operation, contributes significantly to this efficiency. At the same time, the active noise control (ANC) system largely counteracts unwanted noise by broadcasting targeted cancellation sounds into the vehicle interior via the sound system's loudspeakers. Active engine mounts simultaneously offset low-frequency vibrations via countermeasures.

The seven-speed S tronic and quattro permanent all-wheel drive are standard equipment in all three new S models; the latter operates in conjunction with torque vectoring. Upon request, Audi will complement it with the sport differential, which actively distributes power between the rear wheels. adaptive air suspension sport is also standard. This suspension's stiff setup with controlled damping lowers the vehicle body of the S7 Sportback by ten millimeters (0.39 in) and that of the S6 by 20 millimeters (0.79 in). The Audi drive select dynamics system incorporates not only the air suspension but also optional components such as the sport differential and dynamic steering. The driver can vary its operation step-by-step.



AUDI S7 (PHOTO: AUDI AG)

FOURTITUDE.COM 4

Wheels with the format 8.5 J x 19 come with 255/40 tires. Black brake calipers with S6/S7 logos encircle the front disc brakes. Upon request, Audi will supply ceramic carbon-fiber brake discs and wheels up to 20 inches in diameter (S7 Sportback: up to 21 inches).

In addition to the large wheels, other exterior details on the bumpers, single-frame radiator grille and exhaust tailpipes in particular as well as exterior mirrors in aluminum look confirm the status of the new S models. Xenon plus headlights with LED daytime running lights and LED rear lights are standard. The bodies of all three models consist of around 20 percent lightweight aluminum. These bodies excel due to their low weight, outstanding crash safety, high torsional rigidity and sophisticated aerodynamics.

Black throughout, the interior is sportily elegant; instrument dials are gray and the needles white. Trim parts in aluminum look, plus door sill trims and bezels made of aluminum, are minor highlights. Electrically adjustable sports seats are standard equipment for drivers and front-seat passengers in the new Audi S6 and Audi S6 Avant; the S7 Sportback has S sports seats with integrated head restraints.

Additional standard equipment in all three models includes a four-zone, automatic climate-control system, the Audi pre sense basic safety system, and MMI Radio with Audi sound system.

High-end options range from a head-up display through an ambient lighting package to the driver-assistance systems such as adaptive cruise control with stop & go function and the night vision assistant, which highlights detected pedestrians. The Audi S6, the S6 Avant and the S7 Sportback are also best-in-class regarding infotainment systems. The top-shelf solution is MMI Navigation plus with an innovative touchpad, MMI touch. It can be enhanced by means of the Bluetooth car phone online, which allows passengers to enjoy unrestricted online connectivity thanks to a WLAN hotspot. Audi connect provides drivers with customized services such as Audi online traffic information and Audi music stream, a new Internet radio app. The new S models will be available at dealerships early this summer. In Germany, the Audi S6 costs 72,900 euros, the S6 Avant 75,250 euros and the S7 Sportback 79,900 euros.



AUDI S6 (PHOTO: AUDI AG)

FOURTITUDE.COM 4

AT-A-GLANCE: Audi S6, Audi S6 Avant and S7 Sportback

**Drivetrain**

- All-new twin-turbo V8 developing 309 kW (420 hp), 550 Nm (405.66 lb-ft) of torque
- Innovative layout of the cylinder heads; two twin-scroll turbochargers
- New cylinder on demand system switches off four cylinders during part-load operation, plus Start-Stop system
- Average fuel consumption of 9.6 l/100 km (24.50 US mpg), S6 Avant: 9.7 l/100 km (24.25 US mpg)
- 0-100 km/h (zero to 62.14 mph) in 4.7 seconds, S6 Sedan: 4.6 seconds
- Seven-speed S tronic with dynamic shifting is standard
- quattro permanent all-wheel drive with torque vectoring; sport differential on the rear axle, upon request

**Chassis**

- adaptive air suspension sport with stiff setup is standard
- Audi drive select (vehicle-dynamics control system) is standard; dynamic steering is optional
- 19-inch aluminum wheels are standard; optional: 20 inches, S7 Sportback: 21 inches; upon request: ceramic brakes

**Body**

- Audi ultra: Body in aluminum-hybrid construction
- Sportily elegant design with flourishes typical of Audi S models
- Cargo space: S6: 530 liters (18.72 cubic ft), S6 Avant: 565 liters (19.95 cubic ft), S7 Sportback: 535 liters (18.89 cubic ft)

**Equipment**

- Xenon plus including all-weather lights; optional: LED headlights
- MMI Navigation plus with MMI touch and an eight-inch color screen as an option
- Alcantara/leather sports seat (standard in the S6); Alcantara/leather S sports seat (standard in the S7 Sportback)
- Exclusive quality of manufacture: aluminum/Beaufort wood decorative inlays
- Numerous innovative assistance systems upon request
- High-end sound system available: Bang & Olufsen advanced sound system (15 speakers and 1,200 watts of power)
- Optional: Head-up display
- One-of-a-kind in its class: an optional, motion-activated lock release switch for the hatch/trunk lid



AUDI S7 (PHOTO: AUDI AG)

FOURTITUDE.COM 4

**THE ENGINE**

The powerful 4.0 TFSI is very efficient and represents a new and trailblazing type of sportiness. Its power rating of 309 kW (420 hp) is available as of 5,500 rpm and – between 1,500 and 5,200 rpm – the twin-turbo V8 continuously transmits 550 Nm (405.66 lb-ft) of torque. On average, though, it consumes less than ten liters per 100 km (less than 23.52 US mpg). Compared to its predecessor model, the new Audi S6 consumes 25 percent less fuel while offering much-improved driving performance.

The highly cultivated 4.0 TFSI, covered by an elegant designer fascia, offers a displacement of 3,993 cc; its bore measures 84.5 (3.33 in) and its stroke 89.0 (3.50 in) millimeters. It has all the typical features of an Audi V engine: The cylinder angle is 90 degrees, the chain drive for the four camshafts and the engine's ancillaries are located on the back.

The cylinder body made of an aluminum/silicon alloy is manufactured by means of low-pressure chill casting, which ensures excellent homogeneity. A bedplate, which is a sturdy frame for the lower bearing bridges of the crankshaft, further boosts the block's rigidity. The V8 is very light: even with all key add-on parts, it weighs just 220 kilograms (485.02 lb).

Like nearly every Audi engine, the 4.0 TFSI embodies Audi's downsizing philosophy: substituting engine displacement with supercharging. One twin-scroll turbocharger per cylinder bank compresses the fresh air. Exhaust-gas ducts from two cylinders each are kept separate in the exhaust manifold and the turbocharger housing; these ducts only converge right at the turbine. This approach eliminates unwanted interactions between the gas columns. As a result, considerable torque is generated faster than otherwise.

The turbocharger and its intercooler are in the inner V of the cylinder banks, instead of their usual external position next to the crankcase. As regards the cylinder heads, the exhaust-gas side is inside and the inlet side outside. This layout ensures compact construction and short gas travel paths, with minimal friction losses. The 4.0 TFSI responds instantaneously when the driver depresses the gas pedal. Sophisticated insulation of the hot components, in particular the manifold, stabilizes the thermal conditions in the inside V.



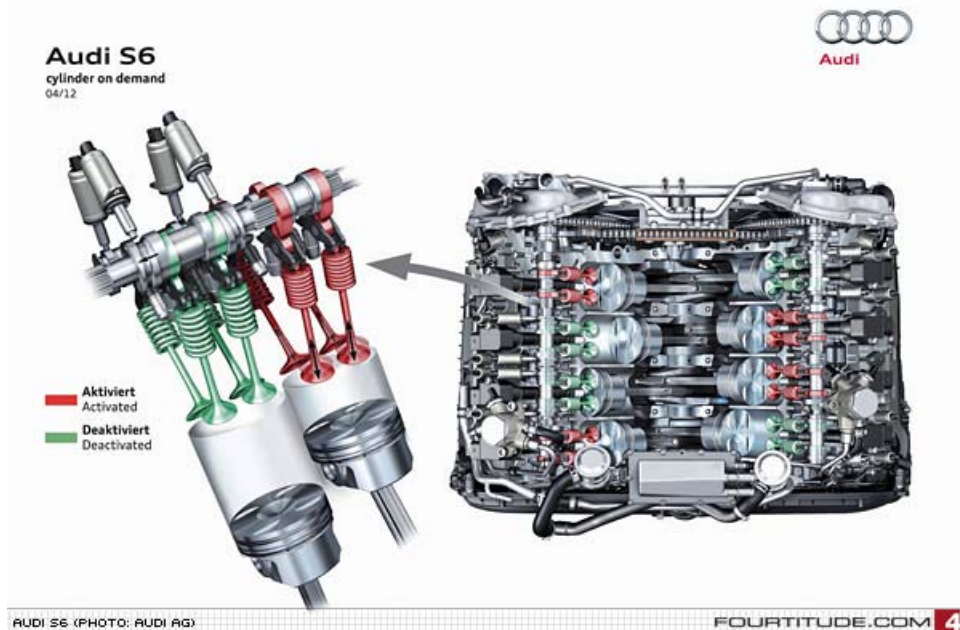

The intake system is external, on the cylinder banks. Switchable flaps in the intake ports mix the incoming air in a cylindrical motion. The directly injected fuel is very turbulent, thus cooling the chambers. The reduced tendency to knock enables a high compression ratio of 10.1 : 1.

#### Impressive package: Technologies of the Modular Efficiency Platform

The 4.0 TFSI uses technologies from Audi's modular efficiency platform, from the Start-Stop system to friction-reducing measures. At the Audi plant in Győr, Hungary, high-end technologies such as panel honing are used to assemble the engine. The piston pins have a fine, diamond-hard carbon (DLC) coating.

Innovative thermal management uses a ball valve to disconnect the water pump while the engine is warming up. The coolant stays in place throughout the engine and the oil heats up quickly, considerably shortening the phase of elevated friction losses. The demand-controlled oil pump varies the oil pressure in two stages.

A groundbreaking technology in the new 4.0 TFSI is the cylinder on demand system. It activates during low to mid-range engine loads. Depending on engine speed, its upper limit ranges from about 25 to 35 percent of maximum torque, about 160 to 250 Nm (118.01 to 184.39 lb-ft). Engine speed must be between 960 and 3,500 rpm, the coolant temperature must be above 30 degrees Celsius (86.00° F) and the transmission's third gear or higher must be engaged.

If these conditions are met, then the system will close the intake valves and exhaust valves of cylinders 2, 3, 5 and 8 in both banks. At the same time, the engine management system shuts off fuel injection and the ignition system. The V8 is now operating as a V4: it fires just twice instead of four times per revolution of the crankshaft (firing order 1 – 4 – 6 – 7). Efficiency in the active cylinders is increased because the operating points are displaced toward higher loads.

In the deactivated cylinders, the pistons continue to move because they are being driven by the crankshaft. Before the valves close, the combustion chambers are again filled with fresh air. This fresh air-fuel mixture results in minimal pressure in the cylinder and, accordingly, a small amount of energy used.

The closing of valves is handled by an enhanced Audi valvelift system (AVS). Its sleeves, which can be adjusted electromagnetically on the four camshafts, have so-called zero cams as additional sections. Since these do not move the cam followers as they rotate over them, the valve springs keep the valves closed. The driver is alerted to four-cylinder status by means of a text notification as well as a green bar in the fuel-consumption indicator on the screen of the driver information system (DIS) in the instrument cluster.

**Audi S6**  
quattro Antriebsstrang  
quattro Drivetrain  
04/12

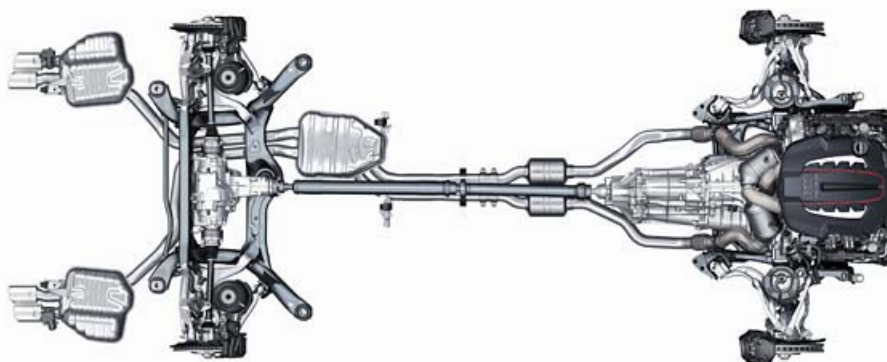

AUDI S6 (PHOTO: AUDI AG)

FOURTITUDE.COM 4

**Mere hundredths of a second: the gear shifts**

As soon as the driver presses firmly down on the gas pedal, the deactivated cylinders cut in again. Switching to and from eight-cylinder mode is so smooth and speedy that it is barely noticeable. Depending on the operating point, shifting lasts between one hundredth and nearly four hundredths of a second.

Audi therefore developed a control-logic system which monitors a driver's steering movements and use of the gas pedal. If this system detects an irregular pattern – while the vehicle is driving around a traffic circle, for example, or during sporty driving on a rural route – then no cylinders are deactivated in order to achieve the best possible efficiency.

The cylinder on demand system is operational at all times, even in the automatic transmission's S mode and Audi drive select's dynamic mode of operation. It offers the very best performance whenever the driver steadily maintains a moderate speed, which is common on many expressways. At 100 km/h (62.14 mph), for instance, it reduces fuel consumption of the new S models by more than ten percent. As per the NEDC (New European Driving Cycle), savings amount to approximately five percent. Including the Start-Stop system, which deactivates an idling engine, savings rise to some twelve percent.

Four-cylinder engines generally do not run quite as quietly as V8 engines; this is true of the new 4.0 TFSI, as well. When the cylinder on demand system is active, the crankshaft drive – depending on the load and engine speed – produces stronger torsional vibrations, which enter the vehicle's interior as structure-borne sound waves and, consequently, as airborne sound. The exhaust system also emits certain humming noises, which cannot be prevented entirely despite an intelligent flap-control system.

**Audi S6**

Aktives Motorlager - Aufbau mit Schwingspulenaktor  
Active engine mount - construction with moving coil  
04/12

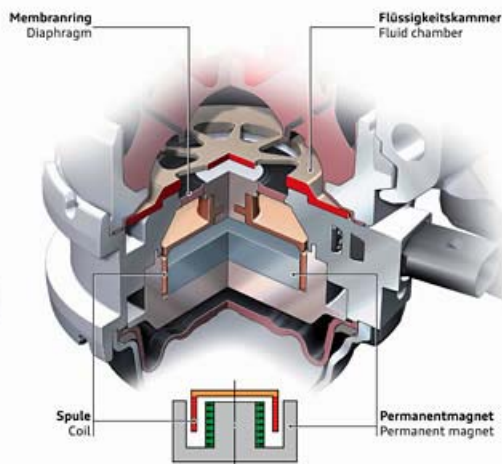

AUDI S6 (PHOTO: AUDI AG)

FOURTITUDE.COM 4

**Targeted interference: Active noise control**

The new Audi active noise control (ANC) technology counteracts unwanted noise by generating a targeted cancellation sound. It puts to use the principle of destructive interference. When two waves of the same frequency overlap, their amplitudes cancel each other out – provided that they are equal and 180 degrees out of phase.

Four small microphones are integrated in the headlining of the new S models. Each of them registers the complete noise spectrum in its immediate area. Based on these signals, the ANC control unit generates a 3D ultrasonic pattern. It also utilizes engine-speed data supplied by the crankshaft sensor.

Whenever the system recognizes unwanted noises in a zone covered by pre-programming, it emits a precisely modulated cancellation sound via the sound system's loudspeakers. It counteracts the noise so effectively that passengers will not hear it. Active noise control works with every sound system supplied by Audi. It works even when the system's volume is low, muted or switched off.

Irrespective of the ANC, the S models come equipped with a second system: active engine mounts. They offset second-order engine vibrations which occur in four-cylinder mode by generating phase-shifted counter-vibrations.

The centerpiece of the active engine mount is an electromagnetic oscillating-coil actuator, which functions like a loudspeaker. Its fast movements – up to one millimeter of stroke between 25 and 250 hertz – are transmitted by means of a rubber diaphragm to the mount's hydraulic fluid, which also bears the engine's vibrations. The vibrations overlap in the fluid and cancel each other out; the point of connection between the mount and the body is quiet.

The control units for the active engine mounts receive their information from two sources. The crankshaft sensor supplies information about engine speed and its signals are used to calculate the phase and frequency of the actuator signal. Acceleration sensors on the engine mounts supply the data which describes the required amplitude. The active engine mounts are also active at idle speed with all eight cylinders in operation. In this case they largely eliminate engine excitation of the fourth order.

In addition, a centrifugal governor in a dual-mass flywheel also helps counterbalance the vibrations caused by the V8 operating in four-cylinder mode. It thus contributes to convenient and efficient driving in these modes of operation.



#### SEVEN-SPEED S-TRONIC

In the three new S models, the 4.0 TFSI is paired with the seven-speed S tronic: this high-end dual-clutch transmission excels thanks to minimal internal friction and high efficiency. Its wide spread allows for not only sporty acceleration in the lower gears but also low rpm at high speeds.

The differential is in front of the clutch and immediately behind the engine. Audi developers were thus able to position the front axle 71 millimeters (2.80 in) closer to the front end than in previous models. This resulted in a long wheelbase and well-balanced axle-load distribution.

The seven-speed S tronic is integrated in the thermal-management system of the 4.0 TFSI via its own heat exchanger. Once the engine has heated enough cooling water, some of the hot water flows on to the transmission-oil cooler. As the oil heats up, friction losses drop.

The seven-speed S tronic consists of two sub-transmissions, which are actuated by two oil-cooled multi-plate clutches. The large K1 clutch located on the outside directs the torque via a solid shaft to the gear wheels for gears 1, 3, 5 and 7. A hollow shaft rotates about the solid shaft. It is connected to the smaller K2 clutch, which is located inside its larger sibling, and which acts on the gear wheels for gears 2, 4 and 6 as well as reverse.

Both transmission structures are continuously active, but only one is connected to the engine at any one time. For example, when the driver accelerates in third gear, the fourth gear is already engaged in the second transmission section. The shifting process takes place as the clutch changes – K1 opens and K2 closes. Shifting gears takes only a few hundredths of a second and is completed with almost no interruption of traction. Shifts are so fluid, dynamic and smooth as to be barely noticeable.

In fully automatic mode, the seven-speed S tronic offers D (Drive) and S (Sport) modes. There is also an optional manual level, which allows the driver to shift via the selector lever or shift paddles on the steering wheel. In manual mode the transmission takes on a sporty tone, which matches the new S models' character.





AUDI S7 (PHOTO: AUDI AG)

FOURTITUDE.COM 4

#### QUATTRO PERMANENT ALL-WHEEL DRIVE

quattro permanent all-wheel drive puts the power in the pedal. Its principal component is a self-locking center differential. Under normal driving conditions, the purely mechanical planetary gear distributes 60 percent of drive torques to the rear-axle differential and 40 percent to the front. In the event of wheel slippage, the differential transfers a majority of the torques to the axle which has better traction – as much as 80 percent to the rear and a maximum of 70 percent to the front.

A standard addition to the quattro drivetrain is an intelligent software solution known as torque vectoring. When the vehicle is being driven fast through a curve, its control unit computes the optimal distribution of power. If it detects that the wheels on the inside of the curve are about to slip, it marginally brakes these wheels – just a slight application of the pads on the disks at minimal pressure is all that it takes.

Torque vectoring works smoothly and continuously. The vehicle remains neutral for a long time at the handling limits; the slight understeer when turning into curves and when accelerating is essentially offset. The electronic stabilization control (ESC) intervenes later and more gently – if it is even necessary at all.

Audi can optionally supply an additional module for the quattro drive of new S models: the sport differential distributes drive forces between the rear wheels in a continuously variable manner. It does this using two superposition gears, each of which comprise two sun gears and an internal gear and are engaged by means of electrohydraulic multi-plate clutches.

The superposition gears rotate ten percent faster than the driveshaft. When the clutch engages, it steplessly imposes the higher rotational speed on the outside wheel; additional torque is obtained from the opposite wheel via the differential. This allows nearly all torque to flow to just one wheel; a difference as high as 1,800 Nm (1,327.61 lb-ft) is possible.

The sport differential guides the vehicle during high-speed cornering to nip in the bud any tendency toward oversteering or understeering. Thanks to its ultra-rapid response time, it functions even faster than the vehicle's electronic stability control (ESC). It is every bit as effective under load as while the vehicle is coasting. It is controlled by Audi drive select, a vehicle-dynamics control system.

**Audi S6**  
quattro Antriebsstrang  
quattro Drivetrain  
04/12



AUDI S6 (PHOTO: AUDI AG)

FOURTITUDE.COM 4

## CHASSIS

Thanks to the adaptive air suspension, the new S models unite a high level of comfort with dynamic handling. The wheel control arms of the chassis and many other components are made of aluminum. The front axle comprises five links per wheel – two transverse links on the upper plane, the support link and control arm in the lower plane, and the track rod.

A five-link suspension can handle longitudinal and lateral forces separately. Its bearings respond smoothly in the longitudinal direction and are stiff in the lateral direction for sporty precision. The control arms are aluminum forgings, which keep the unsprung masses low. The wheel carriers and pivot bearings are also made of this same material. The anti-roll bar, made of a high-strength tube, also reduces weight.

### Highly efficient: Electromechanical power steering

The integrated support for the engine and the front axle serves as the backbone of the front suspension. Made of high-strength steel, it is rigidly bolted to the front end of the car. The all-new electromechanical steering unit, a compact and lightweight part, was placed down low along the wheel center line. The steering track rod's forces are immediate, resulting in agile response, high precision, and explicit road feedback.

Power-steering assistance varies in accordance with the vehicle's speed. The system is extremely efficient because it consumes no energy when driving straight ahead. It also lowers fuel consumption by some 0.3 liters per 100 km. Via help making proper adjustments, the electromechanical steering assists the driver with braking and countersteering on a road that is slippery on only one side.

Audi can optionally install dynamic steering, which – by means of a superimposed gear system – adjusts the steering ratio in a continuously variable manner by nearly 100 percent. At the vehicle's cornering limit, it boosts driving safety and handling via deliberate but minor countersteering.

The rear axle of the new S models follows the track-controlled trapezoidal link principle: a compact layout which provides safe, sporty and comfortable driving. The overhead control arms and the tie rods are aluminum forgings; a steel tube serves as an anti-roll bar. The two trapezoidal links are warm-hardened aluminum castings; the wheel carriers are of chill-cast aluminum.

The struts rest directly on the wheel carriers, which makes possible a high steering ratio and the precise response of the shock absorbers. In addition, the developers succeeded in configuring the four hydraulic bearings, which connect the axle carrier to the body, to enhance ride comfort.



### Precise and luxurious: adaptive air suspension sport

Adaptive air suspension sport is standard in the new S models. This suspension's stiff setup lowers the vehicle body of the S7 Sportback by ten millimeters (0.39 in) and that of the S6 models by 20 millimeters (0.79 in). The system combines an air suspension with controlled damping and also serves as a self-leveling suspension. The air-supply unit – a compressor and a pressure accumulator – is in the rear section.

The twin-tube shock absorbers inside the large pneumatic springs are regulated by complex sensor technology. This management system adjusts its operation within a few milliseconds via the controlling current for the shock-absorber valves.

Its responsiveness is determined by a given road's condition, a driver's style, and the selected mode of Audi drive select.

Audi drive select settings likewise regulate the pneumatic springs. In auto mode, these springs lower the body by 10 millimeters (0.39 in) once the vehicle exceeds 120 km/h (74.56 mph) to increase stability and reduce drag. The body is lower to begin with in dynamic and efficiency modes, whereas comfort mode always maintains the vehicle at its default height. In lift mode, ground clearance can be increased by 20 millimeters (0.79 in) to avoid relatively small obstacles. This function can be selected at speeds up to 80 km/h (49.71 mph).

The Audi drive select system comprises not only adaptive air suspension sport but also the engine management, the seven-speed S tronic, the Audi pre sense basic safety system and the deluxe climate-control system. The same system can also control some optional modules: dynamic steering, sport differential, ACC stop & go and Audi adaptive light. In addition to the auto, dynamic, comfort and efficiency settings, individual mode allows the driver to specify, within certain constraints, his very own profile of preferred settings.

The new S models have a lightweight, durable and strong brake system. All the discs are ventilated; the front ones are perforated, too. Pins made of stainless steel connect cast-iron friction rings to the aluminum brake discs. This concept, borrowed from sports-car engineering, prevents the transfer of temperature peaks, reduces the risk of brake fade and lowers weight.



Black six-piston brake calipers bearing S6/S7 logos on the front axle keep the brake discs in place; single-piston calipers are used at the rear. Upon request, Audi will supply ceramic carbon-fiber brake discs with charcoal-gray calipers. Extremely stable and durable, they collectively weigh some 15 kilograms (33.07 lb) less than comparably sized steel discs.

Electronic stability control (ESC) tightly incorporates dynamic steering, the sport differential and adaptive dampers within its scope of operation. ESC offers a sport mode and can be switched off entirely.

It integrates trailer stabilization and a tire-pressure monitoring display. The auto release function, a subfunction of the electromechanical parking brake, gives the vehicle a boost when starting up a hill.

The S models' wheels have the characteristic five parallel-spoke design. They are in 8.5 J x 19 format with 255/40 tires. Upon request, Audi and quattro GmbH can supply seven additional types of summer and winter wheels measuring 19 or 20 inches in diameter, the latter fitted with 255/35 tires. The S7 Sportback can also be equipped with 21-inch wheels (tires: 265/35). A pressure monitoring system and a repair kit are standard.

The equipment, data, and prices specified in this document refer to the model range offered in Germany. Subject to change without notice; errors and omissions excepted.



## EXTERIOR DESIGN

All three new S models captivate thanks to their sportily elegant design. Each vehicle's outer skin appears taut and aesthetically sculptured. Crisp lines enclose tautly sloped surfaces; the low roof line slopes markedly toward the ground to create a flowing silhouette. Each model is unique.

The platinum-gray single-frame radiator grille, with its angled upper corners, is integrated into the three-dimensional front end. Its chromed, highly detailed, aluminum-look double strips underscore the horizontal struts and, as a result, the width of the vehicle's nose. Prominent contours encircle large air inlets, inside of which crossbars in aluminum look contrast with black grids. There is a flat and wide third air inlet below the single-frame grille and a clear-cut edge tapering downward offsets the bumper.

### Standard: Xenon plus headlights with LED daytime running lights

The xenon plus headlights are standard equipment. Upon request, they can be enhanced by adaptive light, which ideally illuminates the road ahead in every situation. All-weather lights and highway lights are standard here. An alternative is the LED headlights – one glance tells you they are state of the art. Their white light approximates daylight; as a result, they are easier on the eyes at night. The LED headlights are maintenance-free, durable and extremely energy-efficient.

Sill trim strips painted the same color as the body and exterior-mirror housings in aluminum look on the sides of the new S models accentuate their look. V8 T badges adorn the fenders and there are S6/S7 badges on the trunk lid and single-frame grille. The high-gloss package around the side windows imparts small highlights.

At the tail end, the diffuser insert integrates a blade in aluminum look with platinum-gray elements. The exhaust system splits to the left and the right to form slightly elliptical, chromed twin exhaust tailpipes. The rear lights feature LED technology and appear three-dimensional. The taillight, which is made up of 90 light-emitting diodes, appears as a wide, uninterrupted arc due to a series-connected diffuser.

Nine different colors of paint are available. The solid colors are Brilliant Black and Ibis White. The metallic colors are as follows: Ice Silver, Glacier White, Havana Black, Moonlight Blue and Oolong Gray. Phantom Black, pearl effect and Estoril Blue, crystal effect round out the portfolio.



### BODY

The bodies of the new S models follow the Audi ultra lightweight principle: they consist of around 20 percent aluminum. Such aluminum bodies therefore weigh some 15 percent less than comparable all-steel bodies.

Audi uses its unparalleled lightweight expertise to incorporate various semifinished aluminum products. The crossbar in the engine compartment and the cross-members behind the front and rear bumpers are aluminum sections. The front suspension strut domes are tightly integrated aluminum castings. The integrated support behind the instrument panel, the rear shelf, the transverse member in the luggage compartment, the front fenders, the doors, the hood and the trunk lid consist of sheet aluminum.

Ultra lightweight design at Audi means using the right materials in the right places for optimal function. In accordance with this maxim, the bodies also integrate a high quantity of high-end steels in different strength classes. The very best grade includes hot-formed steel units, which are subjected to an extreme and abrupt change in temperature during forming to impart exceptional tensile strength to the steel. They require relatively thin wall thickness and are accordingly lightweight.

Hot-formed steels are found in many locations: in the transition from the front section of the car to the passenger cell, in the A-pillars and the roof arches, in the B-pillars, at the center tunnel and the side sills, at the transition between the side sills and the rear section of the car, and in the floor panel. In many zones, Audi employs tailored blanks – sheets of varying thickness tailored to the requirements of a given component.

The bodies of the new S models boast outstanding static and dynamic torsional rigidity. They thus lay the foundation for superior quality of manufacture, precise handling and a smooth ride. The rear-axle carrier's bearings likewise promote superb vibrational and noise comfort. The windshield integrates a soundproofing safety film and there are three sealing strips per door.

A lined underbody deliberately diverts air and the loss of airflow through the engine compartment is kept to a minimum; this package of measures reduces aerodynamic drag. Visually appealing but effective spoilers on the trunk lid, or a roof spoiler, boost downforce at the rear axle.

The bodies also rank very highly regarding passive safety. The Audi adaptive restraint system and its components work in tandem with the Audi pre sense safety system to provide excellent protection in the interior. There are also two airbags, respectively, in the front, in the backrests of the front seats (and, optionally, in the rear seats, too) and in the roof frame as well as an integral head restraint system and electric belt force limiters for the front seats.



AUDI S6 (PHOTO: AUDI AG)

FOURTITUDE.COM 4

### INTERIOR

Thanks to a long wheelbase of 2,912 millimeters (114.65 in) or 2,914 mm (114.72 in) for the S7 Sportback, even tall people have plenty of room in the three new S models. Their interiors dazzle thanks to workmanship of uncompromising quality, refined finishing, generous equipment packages, simple controls, and a straightforward and slender design.

From the instrument panel to the carpeting, the interior is black throughout. The seats and the headlining are also available in lunar silver. The aluminum door-sill trims are illuminated upon request. The color DIS screen and the MMI monitor display special welcome messages when the car starts up. The leather multifunction steering wheel is enhanced by contrasting-color stitching and shift paddles featuring an aluminum look.

The pedals and the outline of the footrest have stainless-steel inlays. The selector lever's knob and the softkeys of the MMI operating system have a shiny aluminum appearance. A handsome red ring surrounds the Start button, which features red backlighting. S6/S7 badges adorn the door sill trims, the instrument cluster and the key. The gauges are gray and the needles are white.

The sports seats provide solid stability and firm support. Including their four-way lumbar supports, the seats can be adjusted and heated electrically. Embossed logos on the upper backrests in the S6 and black – or silver, if requested – seat covers featuring a combination of Alcantara and Pearl Nappa leather emphasize the vehicle's character of sophisticated sportiness.

Upon request, Audi will supply likewise electrically adjustable S sports seats with high side sections and integrated head restraints. Ultrapremium Valcona leather is an option for them. S sports seats are standard in the S7 Sportback. Yet another option are the multi-adjustable comfort seats, which can be equipped with ventilation and massage units.



AUDI S7 (PHOTO: AUDI AG)

FOURTITUDE.COM 4

Brushed aluminum is standard for the decorative inlays. Bezels are also available in Carbon Atlas and two types of wood: Fine grain ash brown and laminated Beaufort oak. And quattro GmbH offers inlays with a black matte finish. The Audi exclusive range offers additional high-end types of wood, leather trim and ultrapremium operator controls. Another highlight available before long will be aluminum/Beaufort wood decorative inlays.

quattro GmbH offers more options still for an even more personalized vehicle. Examples include Piano finish



decorative inlays and customized leather trim.

The new S models roll off the assembly line with generous standard-equipment packages. In addition to the features already specified, standard equipment includes an on-board computer with efficiency program, the Audi pre sense basic safety system, cruise control, a four-zone, automatic climate-control system, and MMI Radio plus with Audi sound system.

One of the especially appealing optional features is the head-up display, which projects important information – concerning navigation, traffic signs, the car itself and assistance systems – in full color onto the windshield.

In addition, Audi provides options which further enhance on-board comfort. These include an advanced key, an ambient lighting package, special soundproof glazing, power-assisted door locks, sun-protection systems for the rear and an auxiliary heater.



#### DRIVER-ASSISTANCE AND SAFETY SYSTEMS

Audi's assistance and safety systems give even more control to drivers of new S models. Radar-assisted adaptive cruise control with stop & go function regulates the distance to the vehicle ahead. If the threat of a rear-end collision becomes imminent at speeds below 30 km/h (18.64 mph), this system will automatically bring the car to a full stop.

ACC stop & go works in tandem with the Audi pre sense safety system, which is available in a number of different configurations. Audi active lane assist helps the driver to remain in a given lane and Audi side assist aids him during a lane change. The night vision assistant, which highlights detected pedestrians, makes for more relaxed driving at night. The driver information system with rest recommendation recognizes a sleepy driver and advises him to take a break.

Various high-end systems help take the stress out of parking. The park assist system with surround-view camera handles steering. As an option, two small, wide-angle video cameras at the front and rear ensure good views of otherwise hard-to-see spots; the S6 has two more in the outside mirrors. The driver can have the MMI monitor display images from these cameras.



#### INFOTAINMENT SYSTEMS AND AUDI CONNECT

The new S models are also best-in-class regarding infotainment. The top-of-the-range configuration in this category is the MMI Navigation plus system. It is tightly networked with control units of ACC stop & go and the headlights, allowing these systems to quickly and precisely adapt their function to the conditions of a given route.

The MMI Navigation plus is an ultrahigh-performance media unit thanks to its electrically telescoping eight-inch monitor, innovative touchpad controls (MMI touch), a 60-gigabyte hard drive, a DVD drive and whole-word voice input. The Bang & Olufsen advanced sound system, another highlight, controls over 1,200 watts of power and has 15 speakers.

As regards the field of connectivity, the new S models are ahead of the competition, as well. The optional Bluetooth car phone online connects to the internet via UMTS and passengers enjoy unrestricted online connectivity thanks to a WLAN hotspot. The driver has access to tailor-made services such as the latest version of Audi's online traffic information service or appealing Google services: Google Earth, Google Street View and a voice-activated POI (Point Of Interest) search.

Audi music stream, an Internet radio app for smartphones, is a new addition to the Audi connect portfolio. Users can thus tune in to over 5,000 online radio stations and store their favorites on a mobile device. It is operated via WLAN within MMI Navigation plus; the car's sound system handles playback.



#### DETAILS ON THE AUDI S6 AND THE AUDI S6 AVANT

The new Audi S6 and the new Audi S6 Avant excel due to their versatility. They are vehicles for businesspeople, spare-time automobiles and sophisticated sports cars – all in one. The S6 has a curb weight of 1,895 kilograms (4,177.76 lb) and sprints from zero to 100 km/h (62.14 mph) in 4.6 seconds; the S6 Avant weighs 1,950 kilograms (4,299.01 lb) and needs 4.7 seconds. The electronically limited top speed of 250 km/h (155.34 mph) is merely the official figure for both models. The sedan averages 9.6 liters of fuel per 100 km (24.50 US mpg) and the Avant 9.7 l/100 km (24.25 US mpg), which corresponds to CO2 emissions of 225 grams per km (362.10 g/mile) and 226 g/km (363.71 g/mile), respectively.

Both new models have the sportiest proportions in their class. The S6 measures 4,931 millimeters in length (194.13 in) and the S6 Avant 4,934 (194.25 in); each model is 1,874 mm (73.78 in) wide. The sedan is 1,440 millimeters (56.69 in) in height; the Avant is higher by six millimeters (0.24 in). The track of both models is 1,627 mm (64.06 in) at the front and 1,618 mm (63.70 in) at the rear.

The Audi S6 has a trunk capacity of 530 liters (18.72 cubic ft). It is standard that the rear seat backs can be folded down separately. Audi offers an optional load-through hatch with a ski bag. The S6 Avant features 565 (19.95 cubic ft) to 1,680 liters (59.33 cubic ft) of storage capacity. The rear seat backs can be folded down via levers in the luggage compartment; preloaded springs ensure that the backs land gently on the seat cushions.

A rolling cargo-area cover, a net partition, a dirt-resistant tray, and a rail system for securing cargo are standard in the S6 Avant; a load-securing set is available as a special option. Audi can supply a rear electric lid/hatch for both models which can be opened remotely via sensor when the driver moves his foot underneath the rear bumper.

Electrically adjustable sports seats are standard equipment in the new Audi S6 and the new Audi S6 Avant. Audi offers a glass sunroof for the sedan and a large panoramic glass roof for the Avant. The basic price in Germany will be 72,900 euros for the S6 and 75,250 euros for the S6 Avant.



AUDI S7 (PHOTO: AUDI AG)

FOURTITUDE.COM 4

#### DETAILS ON THE AUDI S7 SPORTBACK

It sprints from zero to 100 km/h (62.14 mph) in 4.7 seconds and the electronically limited top speed of 250 km/h (155.34 mph) is merely the official figure. With average fuel consumption of just 9.6 liters per 100 km (24.50 US mpg) and CO2 emissions of 225 grams per km (362.10 g/mile), the Audi S7 Sportback combines fascinating dynamics and high efficiency. It delivers premium performance in a modern and trailblazing manner.

This four-seater has a curb weight of 1,945 kilograms (4,287.99 lb). It is 4,980 millimeters in length (196.06 in), 1,911 millimeters in width (75.24 in) and 1,408 millimeters (55.43 in) in height. Its track measures 1,644 mm (64.72 in) at the front and 1,635 mm (64.37 in) at the rear. Its trunk has between 535 liters (18.89 cubic ft) and 1,390 liters (49.09 cubic ft) of storage capacity. The long, flowing roofline of the S7 Sportback raises the design bar. The harmoniously integrated trunk lid is electric by definition; there is an optional, motion-activated lock release switch.

S sports seats are standard in the Audi S7 Sportback. The standard, double bench seat in the rear is ergonomically contoured.

This five-door coupe will be available at German dealerships for a basic price of 79,900 euros.

**Editor's Note:** As you may have noticed, Audi has begun its launch of the S6 and S7 in Germany. While we won't be able to attend this and share for ourselves impressions of the cars, we're still running all of the PR materials we can get our hands on and this includes the above in-detail press release and on location photography from the Audi Photo Team. We've added shots of each car (S6, S6 Avant and S7 Sportback) to their respective photo galleries and have linked them directly below.

[PHOTO GALLERY: S6 Sedan](#)

[PHOTO GALLERY: S6 Avant](#)

[PHOTO GALLERY: S7 Sportback](#)

FORUMS

For more discussion on this story, click on the link to our discussion forums at the left.

[Top of Page](#)

[Email this article](#)  
[Printer friendly page](#)

Search:   [.Advanced](#)  
[Search](#)

Information © 2005 - 2008 Fourtitude  
All rights reserved.  
Material may not be copied or reprinted without written permission.